

JVC

CAMCORDER

Detailed User Guide

GZ-RY980

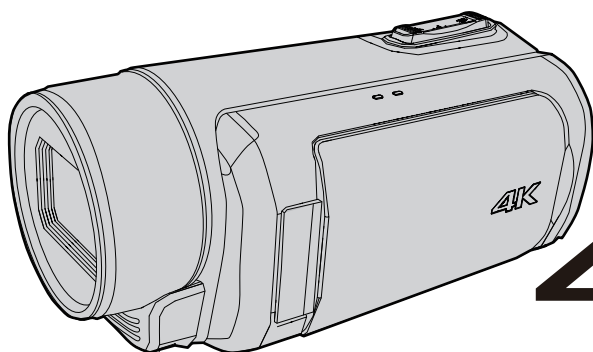

4K
Everio R

Table of Contents

Getting Started

Verifying the Accessories	4
Turning on this Unit	5
Opening the Terminal Cover (SD Card Cover)	5
Charging	6
Grip Adjustment	7
Attaching the Lens Cap	7
Inserting an SD Card	8
Types of Usable SD Card	8
Using the Touch Screen	9
Locking the Screen (when Shooting Underwater)	9
Adjusting the Touch Screen	10
Names of Buttons and Functions on the LCD Monitor	11
Configuring the Initial Settings	13
Readjusting the Clock after Initial Settings are Configured	14
Changing the Display Language after Initial Settings are Configured	14
Holding this Unit	15
Tripod Mounting	15
Using this Unit Overseas	16
Charging the Battery Pack Overseas	16
Setting the Clock to Local Time when Traveling	16
Before Using Underwater or under Low Temperature	18
Cautions on Using Underwater	18
Maintenance after Use	18
Cautions on Using under Low Temperature	18
Other Precautions	18

Recording

Taking Videos in Auto Mode	19
Capturing Still Images	21
Zooming	21
Manual Recording	22
Adjusting Focus Manually (FOCUS)	23
Using the Focus Assist Function	24
Enlarging the Image (EXPANDED) for Focus Adjustment	25
Adjusting Brightness	26
Setting Shutter Speed	27
Setting Aperture	28
Increasing the Light Sensitivity Level	29
Setting Backlight Compensation	30
Setting White Balance	31
Recording Data to Both Slot A and Slot B	33
Slow-motion (High-speed) Recording	34
Shooting under Water	36
Capturing Subjects Clearly (TOUCH PRIORITY AE/AF)	38
Reducing Camera Shake	39
Taking Close-up Shots (TELE MACRO)	40
Special Effect Recording	41
Time-lapse Recording (Time-Lapse Rec)	41
Pre Rec	43
Scene Continuous	44
Using the Self-timer	45
Changing the Mode of Time Code (TC) Recording	47
Checking the Remaining Battery Level and Recording Time	48

Playback

Playing Back Videos	51
Normal Playback	51
Checking the Recording Date and Other Information	54
Playing Back Still Images	55
Slideshow Playback	56
Connecting to and Viewing on TV	57
Connecting via the HDMI Mini Connector	57

Editing

Deleting Unwanted Files	59
-------------------------------	----

Deleting One Scene	59
Selecting and Deleting Multiple Scenes	60
Deleting All Scenes	62
Protecting Video Images	63
Protecting/Canceling Protection of the Displayed (Playback) Scene	63
Protecting/Releasing Protection of Selected Files	63
Protecting/Canceling Protection of All Scenes	65
Trimming Recorded Videos	66
Capturing a Still Image from One Scene in a Video	67

Copying

Backing up Data on a Computer	68
When Using Windows 10 or Windows 8.1	68
When Using Windows 7	70
Using CyberLink PowerDirector	72
Installing PowerDirector	72
Using PowerDirector	73
Verifying System Requirements (Guideline)	74
Dubbing Files to a Disc by Connecting to a Blu-ray Recorder	76

Using Wi-Fi

Wi-Fi Capabilities	77
Precautions on Using Wi-Fi	77
How to Establish a Wi-Fi Connection	78
Ways of Wi-Fi Connection	78
Preparing for Connection	79
Connecting	79
Still Image Transfer	86
View Remote	90
Registering/Deleting Preset Zoom	91
Changing the Settings via a Web Browser	93
Live Streaming	95

Settings Menu

Operating the Menu	97
Operating the Menu	97
Main Menu	98
Camera Function Menu	99
Camera Process Menu	101
Detail Adjust Menu	104
White Balance Adjust Menu	105
TC Menu	106
Monitor Menu	107
Shooting Assist Menu	109
Display Settings Menu	110
A/V Set Menu	112
Video Set Menu	112
Audio Set Menu	112
System Menu	114
Record Set Menu	117
Network Settings Menu	120

Names of Parts 125

Indications on the LCD monitor 128

Troubleshooting 131

When the unit is not working properly	131
Charging	131
Power supply	132
Recording	132
SD Card	133
Playback	133
Editing/Copying	134
Computer	134
Screen/Image	135
Other Problems	135
Error Message	136

Maintenance	137
Specifications	138
Trademarks	140

Verifying the Accessories

If any of the items are missing or defective, consult your JVC dealer or the nearest JVC service center.

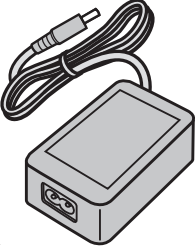
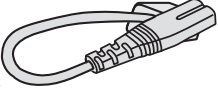
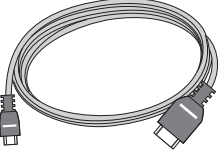
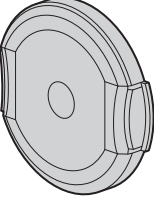
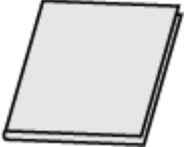
Illustration	Description
	<p>AC Adapter UNI318-0530</p> <ul style="list-style-type: none"> Charges this unit. It can also be used when recording or playing back videos indoors.
	<p>Power Cord</p> <ul style="list-style-type: none"> Connect the power cord to the AC adapter.
	<p>HDMI Mini Cable</p> <ul style="list-style-type: none"> Connects this unit to a TV to play back recorded images on the TV in a better quality.
	<p>Lens Cap</p> <ul style="list-style-type: none"> Attach the lens cap when this camera is not used or during transportation.
	<p>Basic User Guide</p> <ul style="list-style-type: none"> Read well and keep in a safe place where it can be accessed easily when necessary.

Memo :

- Application software programs can be downloaded from CyberLink's website.

"Using CyberLink PowerDirector" (☞ p. 72)

- SD cards are sold separately.

"Types of Usable SD Card" (☞ p. 8)

- When using the AC adapter overseas, please prepare a commercially available converter plug for the country or region of visit.

"Charging the Battery Pack Overseas" (☞ p. 16)

Turning on this Unit

Open the LCD monitor to turn on this unit.
To turn off the power, close the LCD monitor.

■ To turn on the power

Open the LCD monitor.
(Open carefully.)

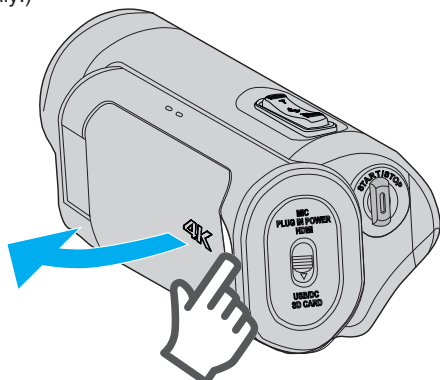

■ To turn off the power

Close the LCD monitor.
(Close carefully.)

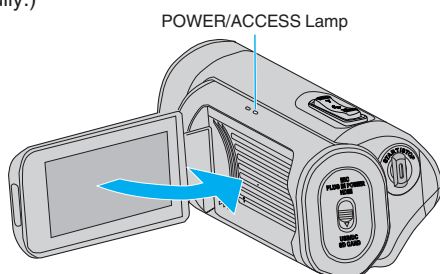

The POWER/ACCESS lamp goes off and the power is turned off.
The power can also be turned off from the menu.
“Operating the Menu” (p. 97)

Memo :

- Set Demo mode to “Off” before using.
“Demo Mode” (p. 115)
- When “Auto Power Off” is set to “On”, this unit turns itself off automatically to conserve power when it is not operated for 5 minutes. (When using the AC adapter, this unit goes into standby mode.)
“Auto Power Off” (p. 115)
- If “LCD Closed Recording” is enabled, this unit does not turn off when the LCD monitor is closed during recording or while it is connected to Wi-Fi. (The power turns off when Wi-Fi is disconnected.)
“LCD Closed Recording” (p. 115)

Opening the Terminal Cover (SD Card Cover)

■ To open

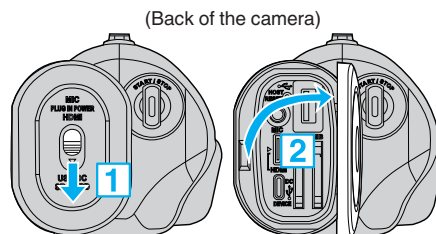

1 Slide the cover lock downward.

- The cover slides to the left automatically.

2 Lift the cover slowly.

■ To close

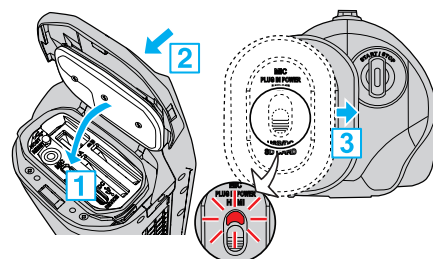

Not properly closed if the red mark is visible.

1 Flip down the cover slowly while making sure the gray waterproof seal fits into the opening at the terminals.

2 Press the entire cover against the camera with equal force and firmly attach the cover completely.

3 Slide the cover until it clicks into place.

(The cover is not properly closed if the red mark on the cover lock is visible.)

Caution :



- Ensure that the terminal cover and the gray waterproof seal are not damaged and that there are no foreign materials (such as hair, lint, sand or dust) adhered on the cover.
- Stop using the unit underwater if there are damages to the cover, etc. and consult your JVC dealer or the nearest JVC service center.
- Do not apply excessive force when opening/closing the terminal cover.
- Read the “Cautions on Using Underwater” (p. 18) before using the camera underwater or in places exposed to water droplets.

Charging

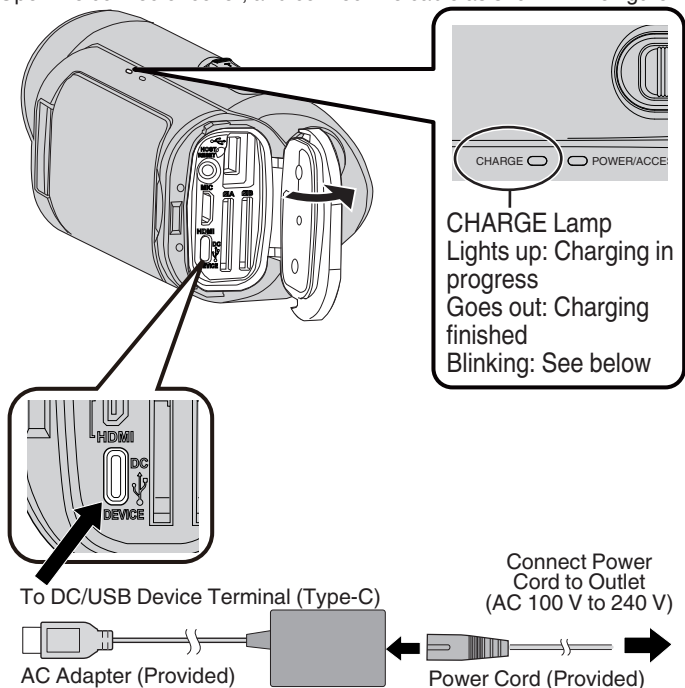
This unit is equipped with a built-in battery. Open the connector cover, and connect the cable as shown in the figure.



Caution :

- The built-in battery is not charged at the time of purchase.
- At the time of purchase or in case of the battery is not used for a long period of time, the charging time will be longer than usual.
- Charging time: Approx. 5 hours (when charging at 25°C)
- The battery cannot be charged outside the room temperature range of 10°C to 35°C. The CHARGE lamp blinks slowly as a notification if charging does not start. If the temperature increases or decreases during charging, the CHARGE lamp will blink slowly and charging will stop. When this occurs, charge the camera again within the above room temperature range.
- Using the supplied AC adapter allows charging to be performed concurrently during recording or playback. (Charging time may be longer than usual or charging may not be successful in some cases.) If the internal temperature rises when using the unit, stop the charging temporarily. (The CHARGE lamp blinks slowly when this occurs.)
- If malfunctions (such as overvoltage) occur, charging will stop. In these cases, CHARGE lamp blinks quickly as a notification.
- During charging, the  icon on the screen changes to  to indicate that charging is in progress. (when the provided AC adapter is used)
- When the recording time becomes extremely short even when the battery is fully charged, the battery needs to be replaced. For details on replacing the built-in battery (subject to a fee), consult the nearest JVC service center.

Using a Power Bank

Connecting to a power bank charges the built-in battery of this unit and supplies the power during recording.

- Usable power bank
 - Output rating: 5 V, 3 A or higher
 - Battery capacity: 10000 mAh or more (recommended)
 - Power bank that comes with a USB Type-C terminal or a cable with a USB Type-C plug on one end

* This unit is not guaranteed to operate with all power banks that meet the above requirements.

Similar to the AC adapter, connect the cable of the power bank to the DC/USB device terminal (Type-C).

Caution :

- Refer to “Caution” under the “Charging” section. The charging time is about the same as the AC adapter.
- This camera may not be fully charged if the power bank used for charging it has a small capacity.
- Do not apply strong force to the DC/USB terminal when recording with the power bank connected. In addition, take note that the Waterproof, Dust-proof, Drop-proof and Freeze-proof functions do not function when the terminal cover is opened.

Memo :

- For details on using the power bank, refer to the instruction manual of the power bank.
- For questions on the power bank, please consult the dealer or manufacturer of the power bank.

Grip Adjustment

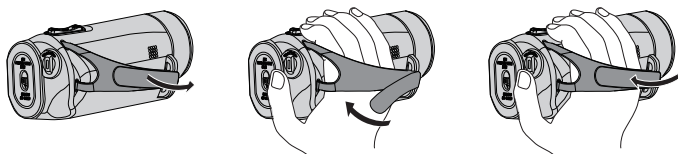

- ① Open the belt ② Adjust the length of the belt ③ Fasten the belt

- 1 Open the belt
- 2 Adjust the length of the belt
- 3 Fasten the belt

Caution :

- Be sure to fasten the grip belt properly.
If the belt is loose, this unit may drop and result in injuries or damages.

Attaching the Lens Cap

Attach the cap to protect the lens when not shooting.

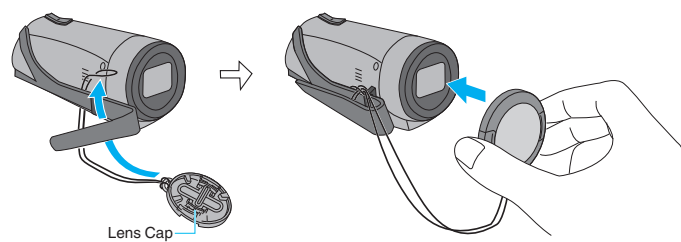

■ During recording

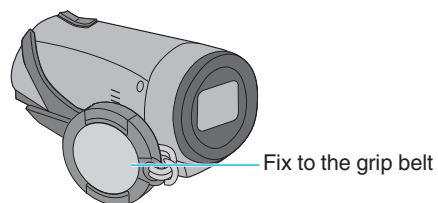

Inserting an SD Card

Before shooting, insert a commercially available SD card (4 GB to 512 GB) into Slot A, Slot B or both slots.

“Types of Usable SD Card” (p. 8)

“Approximate Video Recording Time” (p. 50)

- 1 Close the LCD monitor to turn off this unit.

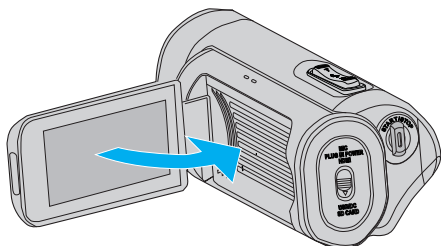

- 2 Open the terminal cover.

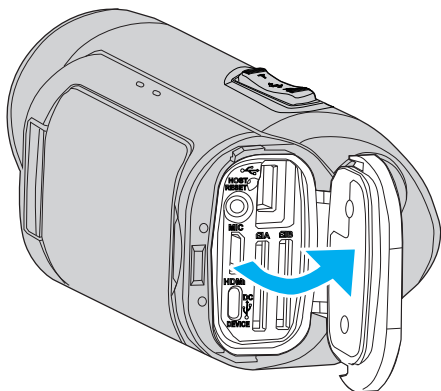

- 3 Insert an SD card.

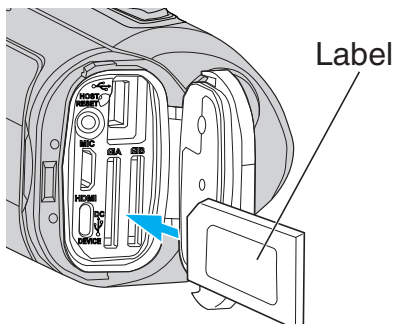

Warning

- Make sure not to insert the SD card in the wrong direction. It may cause damage to the unit and SD card.
- Before inserting or removing the SD card, close the LCD monitor and ensure that the POWER/ACCESS lamp goes off.
- Do not touch the metal contact area when inserting the SD card.

Caution :

- When “System” is set to “HD”, videos with “Frame Rate” at 60p/60i and 50p/50i cannot be mixed on the same card.
- Before inserting a new SD card, check if the “Frame Rate” has been set to the frame rate for shooting. (p. 128)
To change the “Frame Rate”, do so before inserting a new card.

Memo :

- To use a new SD card or SD card used on other devices, it is necessary to format (initialize) the SD card using “Format SD Card” from the “System” menu.

“Format SD Card” (p. 114)

Removing the Card

Push the SD card inward once, then pull it out straight.

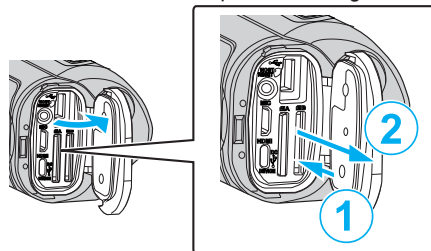

Types of Usable SD Card

The following SD cards can be used on this unit.

Operations are confirmed on the SD cards from the following manufacturers.

- Panasonic
- TOSHIBA
- SanDisk

SDHC Card



- For HD recording, use an SDHC card (4 GB to 32 GB) that is of Class 4 (CLASS 4) or higher.
- During 4K or High-Speed recording, use an SDHC card (4 GB to 32 GB) that is of Class 10 (CLASS 10) or higher.

SDXC Card



- For HD recording, use an SDXC card (up to 512 GB) that is of Class 4 (CLASS 4) or higher.
- During 4K or High-Speed recording, use an SDXC card (up to 512 GB) that is of Class 10 (CLASS 10) or higher.

Memo :

- This unit is not guaranteed to operate with all SD cards.
- Do not use a miniSD card or microSD card (even if the card is inserted in an adapter). It may cause malfunction.
- To protect the data, do not touch the terminals of the SD card.
- UHS-I SDHC/SDXC cards can be used in the same manner as standard SDHC/SDXC cards.
UHS Speed Class is not supported.
- SD card that is used for recording or edited using this unit cannot be played back or edited on other camcorder units.
- When "4 GB Spanning" is set to "Off (SDXC)" using an SDXC card, it is possible to record long videos without splitting the file into units of 4 GB.
- Both videos and still images can be recorded on one SD card.
- A maximum of 600 video scenes can be recorded on one SD card.
When the upper limit is reached, the remaining recording time is displayed as "0min" and no further recordings can be made regardless of "Approximate Video Recording Time" (p. 50) .
A maximum of 4000 still images can also be recorded on one SD card.

When your computer cannot recognize the SDXC card

Confirm and update the OS of your computer.

Windows 7	Download and install the updating program (KB976422) from the following URL. 32 bit version http://www.microsoft.com/downloads/details.aspx?displaylang=ja&FamilyID=3ee91fc2-a9bc-4ee1-aca3-2a9aff5915ea 64 bit version http://www.microsoft.com/downloads/details.aspx?displaylang=ja&FamilyID=73f766dd-7127-4445-b860-47084587155f http://www.microsoft.com/downloads/en/details.aspx?FamilyID=3ee91fc2-a9bc-4ee1-aca3-2a9aff5915ea http://www.microsoft.com/downloads/en/details.aspx?FamilyID=73f766dd-7127-4445-b860-47084587155f
Mac OS X 10.4 Tiger / Mac OS X 10.5 Leopard	Not compatible.
Mac OS X 10.6 Snow Leopard	Update the OS version to 10.6.5 or later.

Using the Touch Screen

The LCD monitor of this unit is a touch panel which enables operations by touching the screen with your finger.

The operation buttons, thumbnails, and menu items are displayed on the screen according to each mode (recording/playback/setting).

Tap the button (icon) or scene (file) on screen **A** to make a selection.

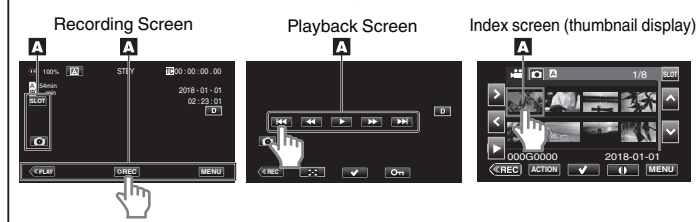
**Memo :**

- The touch screen of this unit is pressure-sensitive. When the touch screen does not respond smoothly, apply slightly more force to your fingertip.
- Do not press or rub with excessive force.
- Do not operate the touch screen using an object with a sharp tip.
- Only one point on the screen can be tapped at any one time.
- Perform "Touch Screen Adjust" if the reactive area of the screen is misaligned with the touched area.
"Adjusting the Touch Screen" (p. 10)
- You cannot operate the touch screen under water. Lock the screen to prevent operation errors.
"Shooting under Water" (p. 36)

Locking the Screen (when Shooting Underwater)

Lock the screen before using this unit underwater to prevent operation errors on the touch screen due to water pressure.

- Once the screen is locked, operations on the touch screen except **f** are disabled.
- The START/STOP (recording) button and the zoom lever can be used while the screen is locked.

Setting "Screen Lock"

- 1 Check that the unit is in the recording mode.
- 2 Tap "MENU".
- 3 Select "System" and tap "SET".
- 4 Select "Screen Lock" and tap "SET".

- The **f** button appears on the screen.

**To Cancel "Screen Lock"**

Tap the **f** button.

Memo :

- "Screen Lock" cannot be set for the following cases:
 - During recording
 - When connected to Wi-Fi
 - When "System" is set to "High-Speed"
 - When "Rec Mode" is set to "Time-Lapse Rec"

Adjusting the Touch Screen

Adjust the response position when the touch screen is touched.

1 Tap "MENU".



2 Select "System" with \wedge or \vee , followed by tapping "SET".

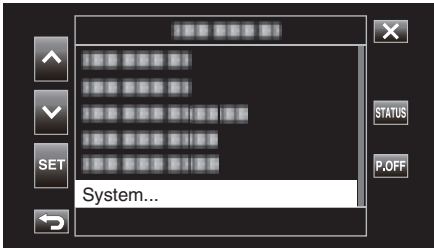

3 Select "Touch Screen Adjust" with \wedge or \vee , followed by tapping "SET".

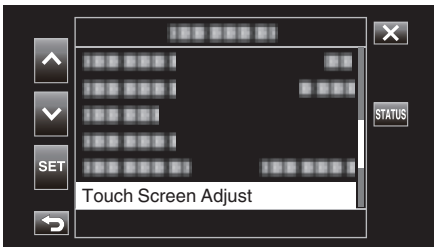

• The touch screen adjustment screen appears.

4 Tap "+". (3 times in total)

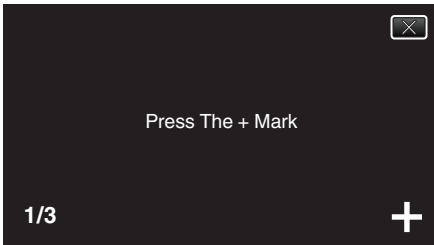

- Keep tapping "+" as its position changes with every tap.
- If areas other than the "+" mark are tapped, errors will occur. Make sure to tap the "+" mark.

5 Tap "+" again to confirm the adjusted positions. (3 times in total)



- Keep tapping "+" as its position changes with every tap.

6 Tap the screen.

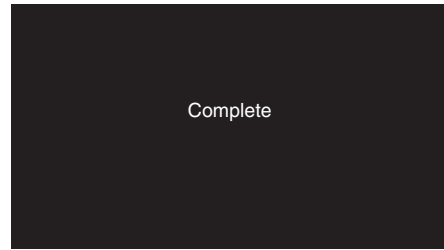

- Setting ends and returns to the menu screen.

Caution :

- Do not tap areas other than the "+" mark during touch screen adjustment (steps 4 - 5). Doing so may cause the touch screen to malfunction.

Memo :

- Adjust by lightly tapping with a corner of an SD card, etc.
- Do not press with an object with a sharp tip or do not press hard.

Names of Buttons and Functions on the LCD Monitor

Recording Screen

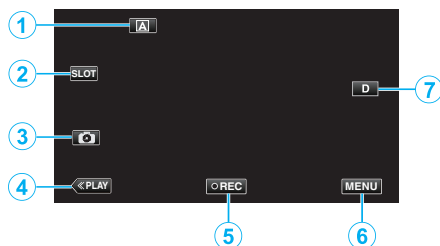

- 1** Auto/Manual Selection Button
 - Switches between the Auto and Manual modes.
- 2** Card Slot Selection Button
 - Switches the card slot to use between Slot A and Slot B when SD cards are inserted into both slots.
- 3** Still Image Recording Button
 - Records still images while in the recording standby mode.
 “Capturing Still Images” (☞ p. 21)
- 4** Playback Mode Button
 - Switches to the playback mode.
- 5** Recording Start/Stop Button
 - “Recording Start/Stop Button” (☞ p. 20)
 - **REC** (black dot): Video Recording Start Button
 - **REC** (red dot): Video Recording Stop Button
- 6** Menu Button
 - “Operating the Menu” (☞ p. 97)
- 7** Display Button
 - Switches the display between full (**D_F**) and simple (**D**) with every tap of the button.
 - Simple display: Some displays disappear automatically when the screen is not operated.
 - Full display: Displays everything. The display button changes from **D** to **D_F**.

Playback Screen (Video)

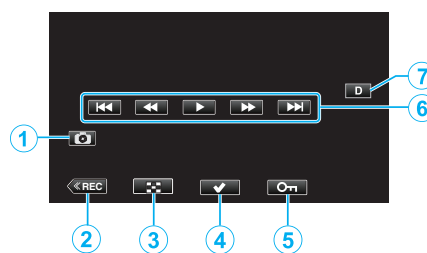

- 1** Video Scene Capture Button
 - Displayed when playback is paused.
 - Saves one scene of the video being played back as a still image.
- 2** Recording Mode Button
 - Switches to the recording mode.
- 3** Index Screen (Thumbnail Display) Button
 - Returns to the index screen (thumbnail display).
- 4** Select Button
 - By turning on the “Select” button to select the video that is currently playing, operations such as protect and delete can be performed easily. Tapping the button each time toggles between the selected and deselected state.
- 5** Protect Button
- 6** Operation Buttons
 - “Operation Buttons for Video Playback” (☞ p. 52)
- 7** Display Button
 - Switches the display between full (**D_F**) and simple (**D**) with every tap of the button.
 - Simple display: Some displays disappear automatically when the screen is not operated.
 - Full display: Displays everything. The display button changes from **D** to **D_F**.

Playback Screen (Still Image)

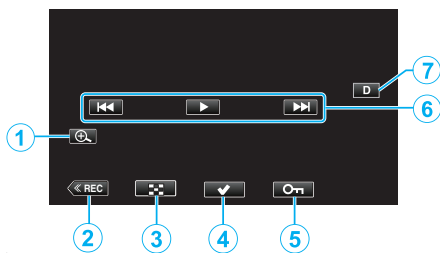

- 1** Enlarge Display Button
 - Enlarges the still image that is being played back.
- 2** Recording Mode Button
 - Switches to the recording mode.
- 3** Index Screen (Thumbnail Display) Button
 - Returns to the index screen (thumbnail display).
- 4** Select Button

By turning on the “Select” button to select the still image that is currently playing, operations such as protect and delete can be performed easily. Tapping the button each time toggles between the selected and deselected state.
- 5** Protect Button
- 6** Operation Buttons

“Operation Buttons for Still Image Playback” (p. 55)
- 7** Display Button

Switches the display between full (D?) and simple (D) with every tap of the button.

 - Simple display: Some displays disappear automatically when the screen is not operated.
 - Full display: Displays everything. The display button changes from D to D?.

Index Screen (Thumbnail Display) Display

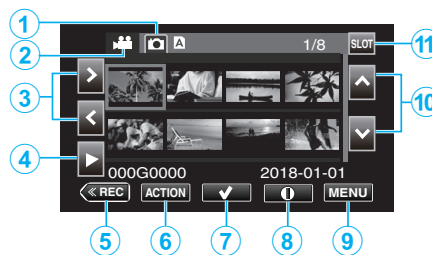

- 1** Still Image Playback Mode Selection Button
 - Switches to the Still Image Playback Mode screen.
- 2** Video Playback Mode Selection Button
 - Switches to the Video Playback Mode screen.
- 3** Left/Right Arrow Keys
 - Moves the cursor to the left or right.
- 4** Playback Button
- 5** Recording Mode Button
 - Switches to the recording mode.
- 6** Action Menu Button

“ACTION” Menu (Video)” (p. 53)
 “ACTION” Menu (Still Image)” (p. 56)
- 7** Select Button

For selecting the scene (file) to protect or delete. Tapping the button each time toggles between the selected and deselected state.
- 8** Detailed Information Screen Selection Button
 - For viewing the recording information.
- 9** Menu Button
 - Displays the menu.
- 10** Up/Down Arrow Keys
 - Moves the cursor upward or downward.
- 11** Slot Selection Button
 - Switches the card slot to Slot A or Slot B.

Menu Screen (Recording Mode)



- 1 Up/Down Arrow Keys
 - Moves the cursor upward or downward.
- 2 Set Button
 - Confirms the selected item.
- 3 Previous Button
 - Returns to the previous screen.
- 4 Power Off Button
 - Pressing the button for approximately 2 seconds or longer turns off the power.
- 5 STATUS Screen Display Button
 - Displays the screen for check the current settings.
- 6 Close Button
 - Exit the menu.

Configuring the Initial Settings

When the power of this unit is turned on for the first time, it is necessary to select a display language and configure the internal clock for the initial settings. All operations are disabled until initial settings are configured.

- 1 Open the LCD monitor.

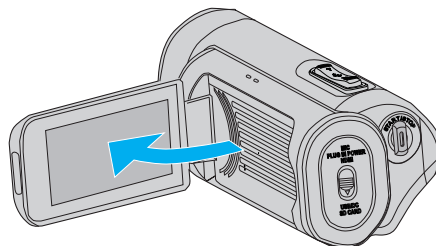

- The power turns on, and a language selection screen appears.

- 2 Configure the language to use.

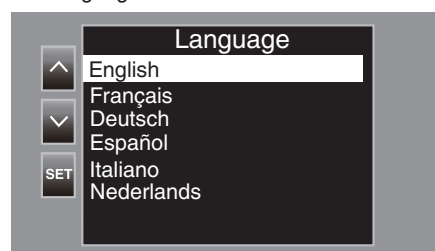

- Tap \wedge or \vee to select the language to use, followed by tapping "SET".

Memo :

- The Language screen appears when the power of this unit is turned on for the first time, or when "System"→"FACTORY PRESET" is executed from the menu.
- The menus and messages on the LCD screen are displayed in the selected language.

- 3 Set the time zone and date/time.

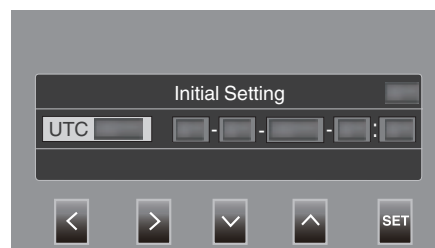

- Move the cursor with $\langle \rangle$ to select an item.
- Use $\wedge \vee$ to change the setting.

Memo :

- The Initial Settings screen appears when the power of this unit is turned on for the first time, or when the unit is powered on again about a month after the battery ran out.
- Even when the power is turned off, the configured date/time data is stored using the built-in battery.

- 4 After the settings are configured, tap "SET" according to the time signal.

- The clock is set to 0 seconds of the date and time entered.

Memo :

- The configured date/time data can be displayed on the LCD screen or recorded to an SD card.
- The value of the year can be set in the range of "2000" to "2099".

Readjusting the Clock after Initial Settings are Configured

Setting the Date/Time

1 Tap "MENU".



2 Select "System" with \wedge or \vee , followed by tapping "SET".

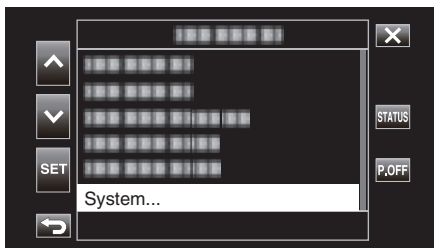

3 Select "Date/Time" with \wedge or \vee , followed by tapping "SET".

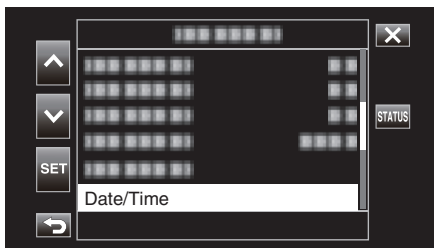

4 Set the date and time.

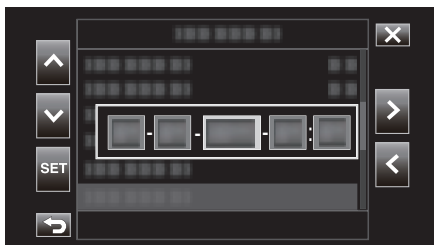

- Move the cursor with $\langle \rangle$ to select an item.
- Use $\wedge \vee$ to change the setting.

5 After the settings are configured, tap "SET" according to the time signal.

- The clock is set to 0 seconds of the date and time entered.

Changing the Display Style

Changes the date/time display style.

■ Date Display (Date Format) Setting

The date display can be changed in "Monitor"→"Display Settings"→"Date Style".

■ Time Display (Time Format) Setting

The time display can be changed in "Monitor"→"Display Settings"→"Time Style".

Changing the Display Language after Initial Settings are Configured

The language on the display can be changed. Change the language in the "Language" item of the menu.

1 Tap "MENU".



2 Select "System" with \wedge or \vee , followed by tapping "SET".

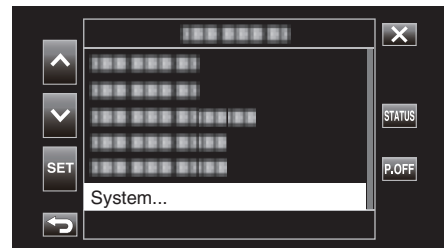

3 Select "Language" with \wedge or \vee , followed by tapping "SET".

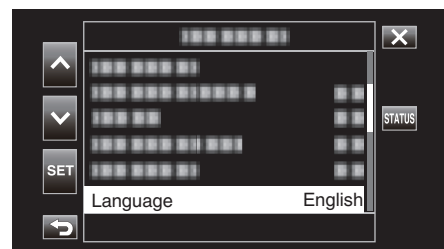

4 Select the desired language and tap "SET".

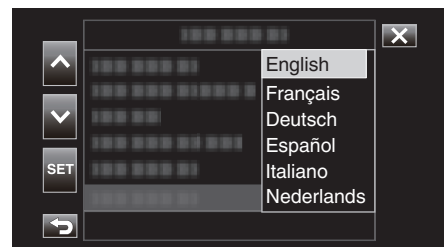

Holding this Unit

When holding this unit, keep your elbows close to your sides to prevent camera shake.

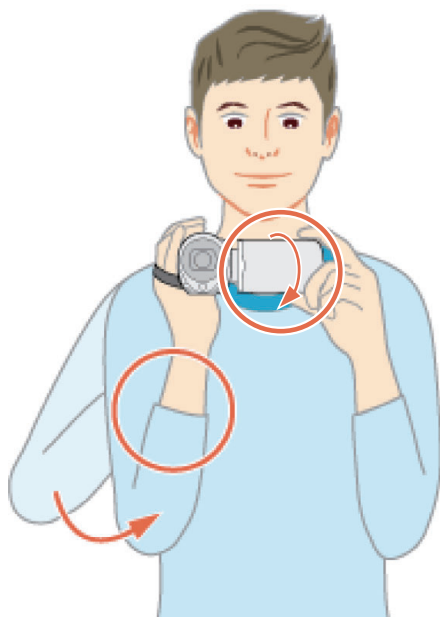

- Hold the LCD monitor with your left hand and adjust the angle accordingly. Holding the LCD monitor with your left hand helps to stabilize the camera for recording.

Caution :

- The photographer should pay attention to the surroundings during shooting, making sure that he/she is in no danger of falling or collision with another person or vehicle.
- Be careful not to drop this unit during transportation.
- Guardians should pay close attention when this unit is used by children.

Tripod Mounting

This unit can be mounted on a tripod (or monopod). This is useful for preventing camera shake and recording from the fixed position.

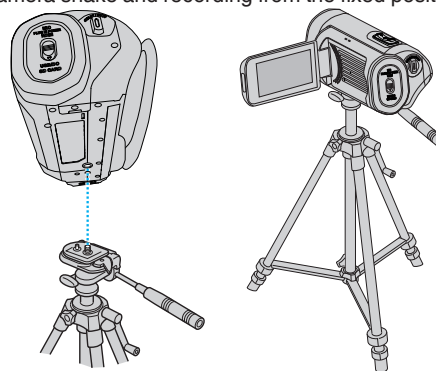

- To prevent this unit from falling off, check the tripod mounting screw holes and positioning holes on the unit carefully before mounting, and turn the screws until they are fastened firmly.

Caution :

- To prevent injuries or damages which may result if this unit falls off, read the instruction manual of the tripod (or monopod) to be used and make sure that it is securely attached.
- In strong wind conditions and when placed at an unstable location, there is a risk of the tripod toppling and falling.
- Please check beforehand if the use of a tripod is allowed as it may be prohibited depending on the shooting location.

Memo :

- It is recommended to use a tripod or monopod when recording in conditions prone to camera shake (such as in dark places or when zoomed to the telephoto end).
- When a tripod is used for recording, set "DIS" to "Off".
"Reducing Camera Shake" (☞ p. 39)

■ Time Zone of Major Cities

-11:00	MIDWAY ATOLL		
-10:00	HAWAIIAN ISLANDS	HONOLULU	TAHITI
- 9:00	ALASKA	ANCHORAGE	
- 8:00	VANCOUVER	SEATTLE	LOS ANGELES
- 7:00	DENVER	PHOENIX	CALGARY
- 6:00	CHICAGO	HOUSTON	MEXICO CITY
- 5:00	TORONTO	NEW YORK	BOGOTA
- 4:00	MANAUS	SANTIAGO	
- 3:30	NEWFOUNDLAND		
- 3:00	RIO DE JANEIRO	SAO PAULO	BUENOS AIRES
- 2:00	FERNANDO DE NORONHA		
- 1:00	AZORES		
0:00	LONDON	CASABLANCA	LISBON
+ 1:00	BERLIN	PARIS	WARSAW
+ 2:00	HELSINKI	ISTANBUL	CAIRO
+ 3:00	MOSCOW	RIYADH	NAIROBI
+ 3:30	TEHRAN		
+ 4:00	DUBAI	ABU DHABI	
+ 4:30	KABUL		
+ 5:00	ISLAMABAD	KARACHI	MALE
+ 5:30	DELHI	CALCUTTA	BOMBAY
+ 6:00	DHAKA		
+ 6:30	YANGON		
+ 7:00	BANGKOK	JAKARTA	
+ 8:00	BEIJING	HONG KONG	SINGAPORE
+ 9:00	TOKYO	SEOUL	
+ 9:30	ADELAIDE	DARWIN	
+10:00	GUAM	SYDNEY	
+11:00	SOLOMON ISLANDS	NEW CALEDONIA	
+12:00	FIJI	AUCKLAND	WELLINGTON
+13:00	SAMOA		

Before Using Underwater or under Low Temperature

This section describes the precautions and methods of maintenance when using the unit underwater or under low temperature conditions.

“Cautions on Using Underwater” (☞ p. 18)

“Maintenance after Use” (☞ p. 18)

“Cautions on Using under Low Temperature” (☞ p. 18)

“Other Precautions” (☞ p. 18)

Cautions on Using Underwater

Please take note of the followings when using this unit near water or underwater.

- **Ensure that the cover is closed tightly.**
“Opening the Terminal Cover (SD Card Cover)” (☞ p. 5)
 - Ensure that the terminal cover and the gray waterproof seal are not damaged and that there are no foreign materials (such as hair, lint, sand or dust) adhered on the cover.
 - Stop using the unit underwater if there are damages to the cover, etc. and consult your JVC dealer or the nearest service center.
- Use the camera within a water depth of 5 m and a duration not longer than 1 hour.

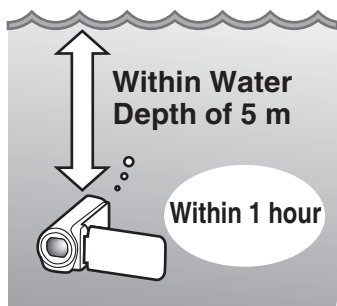

- Do not open/close the cover or insert/remove an SD card or any cables while using underwater or on the beach, or if your hands contain water droplets or sands. Doing so may cause water to enter into the camera or malfunction.
- Do not subject the camera to high pressure or vibration resulted from swift current, waterfall or diving into water.
- The waterproof performance is not guaranteed if the camera is dropped or subjected to other impact shock. If the camera has been subjected to impact shock, consult your nearest service center.
- While shooting underwater, noise generated inside of the camera (zooming sounds, etc) may be picked up. This is not a malfunction.
- Do not immerse into hot spring, or hot water above 40°C. Doing so deteriorates waterproof performance.
- Keep away from hands with sun oil or sun screen. Doing so may cause discoloration or deterioration of material.
- This unit sinks underwater. Fasten the grip belt firmly to prevent losing the camera underwater.
- The accessories are not waterproof.
- Wi-Fi function is not available underwater.
- Do not use the lens filter or conversion lens underwater or at locations where there is water.

Maintenance after Use

After using underwater or in dusty places, rinse the camera with water immediately and dry it completely.

- 1 Ensure that the terminal cover is closed.
- 2 Rinse with clean water.
Soak the camera in a container filled with enough water to immerse the camera completely, and rinse it gently.



- 3 Dry the camera.
Wipe the camera completely with a soft dry cloth and allow it to dry in a well-ventilated and shady location.
- Place the camera with the lens facing downward while the LCD monitor is closed, and leave it for approximately 10 minutes. (By doing so, microphone and LCD part are dried out easily.) Place the camera in a up right position on a dry cloth afterward Close the terminal cover after the camera is dried out completely.
 - Wipe off any foreign materials or water droplets inside the cover.
- * If you leave the camera immersed in salt water or allow water droplets from the salt water to remain on the camera, this may cause corrosion, discoloration or deterioration of waterproof performance.
 - * If you wipe or dry the camera with sand particles adhered, this may cause scratches on the camera.
 - * Do not wash with chemicals, soap, neutral detergents, or alcohol.
 - * Do not dry the camera with a hair dryer or other heat sources. This could impair its waterproof performance.

Cautions on Using under Low Temperature

- The performance of the battery will drop temporarily when the temperature is -10°C to 0°C, this will cause the remaining recording time to shorten.
- Charging cannot be performed when the surrounding temperature is below 10 °C.
- Turning on the camera while it is still cold will deteriorate the performance of the LCD monitor. Problems such as the screen becoming dark momentarily or residual image can occur.
- If snow or water droplets adhere to the camera under sub-zero temperature environment, ice can formed between the gaps around the buttons, speaker or microphone. This will cause difficulty in operating the buttons as well as decrease in the volume level.
- Direct contact with exposed metal part under cold temperature can cause the skin to stick on the metal part resulting in injuries such as frostbite. Do not touch with bare hands.

Other Precautions

- Do not leave the camera under low temperature in cold climates or under high temperature above 40 °C (such as under direct sunlight, inside a vehicle in the hot sun, or near a heater). This will cause deterioration of the waterproof performance.
- Malfunction due to mishandling will void the warranty.
- We are not responsible for any loss of data due to water entering into inside of the camera. Please be forewarned.
- It is recommended to replace the waterproof packing once a year to maintain the waterproof performance. Consult your nearest service center. (Subject to a fee)

Taking Videos in Auto Mode

During Auto recording, the camera automatically adjusts the settings such as brightness and focus to suit the shooting conditions.

- Before recording an important scene, it is recommended to conduct a trial recording.

1 Open the LCD monitor.

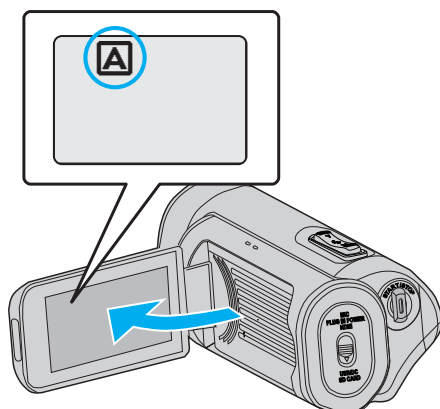

2 Check if the recording mode is set to **A**.



- If the mode is **M** Manual, tap **M** on the recording screen to display the mode switching screen.

Tap **A** to switch the recording mode.

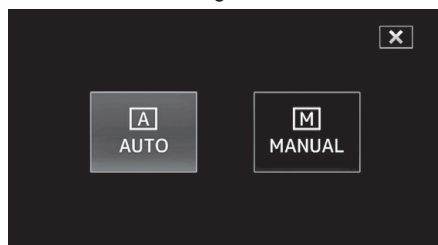

3 Press the START/STOP button to start recording.

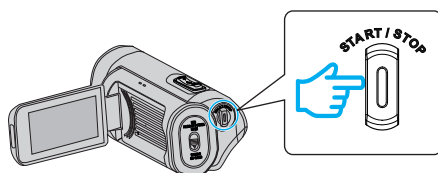

- Press again to stop.
- Some displays disappear after approximately 3 seconds. Use the **D** button to change the displays.

Indications for Video Recording

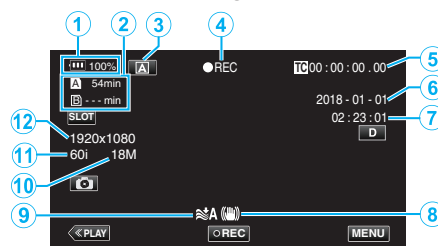

	Display Icon	Description
①	Battery Indicator	Displays the approximate remaining battery power during use. “Checking the Remaining Battery Level and Recording Time” (☞ p. 48)
②	Recording Media	Displays the SD card icon and recordable time. “Checking the Remaining Battery Level and Recording Time” (☞ p. 48)
③	Recording Mode	Displays the current recording mode as A (Auto) or M (Manual). Current shooting mode is displayed.
④	Recording	Appears when recording is in progress. (“STBY” appears when recording is stopped.)
⑤	Time Code	Displays the time code that is recorded to a video. “TC Menu” (☞ p. 106)
⑥	Date Display	Displays the date (year, month and day).
⑦	Time	Displays the current time. “Configuring the Initial Settings” (☞ p. 13)
⑧	DIS	Displays the image stabilizer settings. “Reducing Camera Shake” (☞ p. 39)
⑨	Wind Cut	Displays the wind cut settings. “Wind Cut” (☞ p. 113)
⑩	Bit Rate	Displays the bit rate settings.
⑪	Frame Rate	Displays the frame rate settings.
⑫	Resolution	Displays the resolution that is determined according to the “System” of the recording format.

Operation Buttons for Video Recording

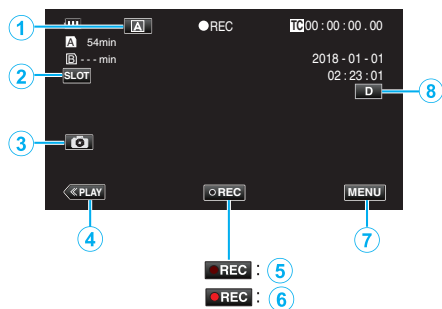

	Operation Buttons	Description
①	Auto/Manual Selection Button	Switches between the Auto and Manual recording modes.
②	Card Slot Selection Button	Switches the card slot to use between Slot A and Slot B.
③	Still Image Recording Button	Tap this button to record a still image during recording standby. “Capturing Still Images” (☞ p. 21)
④	Playback Mode Button	Switches to the playback mode.
⑤/⑥	Recording Start/Stop Button	Functions as the START/STOP button.
⑦	Menu Button	Displays the main menu. “Operating the Menu” (☞ p. 97)
⑧	Display Button	Switches the display between full (D _P) and simple (D) with every tap of the button. <ul style="list-style-type: none"> • Simple display: Some displays disappear automatically when the screen is not operated. • Full display: Displays everything. The display button changes from D to D_P. • When the power is turned off, the display setting will revert to simple display (D).

Caution :

- Do not expose the lens to direct sunlight.
- While this unit can be used with the LCD monitor reversed or the LCD monitor closed with “LCD CLOSED RECORDING” activated, the temperature of this unit rises more easily. Leave the LCD monitor open when using this unit for long periods of time, or in places exposed to direct sunlight or high temperatures.
- The power may turn off to protect the circuit if the temperature of this unit rises too much.
- This unit is a microcomputer-controlled device. Electrostatic discharge, external noise and interference (from a TV, a radio, etc.) might prevent it from functioning properly. In such a case, close the monitor screen to turn off the power and remove the AC adapter, then press the Reset button to reset this unit.

“Resetting this Unit” (☞ p. 131)

- Disclaimer
 - We shall not be liable for any loss of recorded contents when videos or audio cannot be recorded or played back properly due to malfunction of this unit and accessories that come with it or the SD card.
 - Recorded contents (data) that are lost, including loss due to malfunction of this unit, cannot be restored. Please be forewarned.
 - JVC will not be responsible for any lost data.

Memo :

- Check that the remaining recording time in the media is sufficient before you start recording. “Checking the Remaining Battery Level and Recording Time” (☞ p. 48)
If the remaining recording time is not sufficient, save the files on a PC or disc before deleting the files from the unit. “Deleting Unwanted Files” (☞ p. 59)
- Due to the specifications of this unit, continuous recording for a duration of 12 hours or longer is not possible when recording is performed with “System” set to “HD”. Recording stops automatically 12 hours after it is started.
(It may take some time to resume recording.)
- Up to 4GB per video file can be recorded. File recorded using long recordings that exceeds 4GB is split and recorded into several video files. However, recording up to 64 GB or 4 hours is possible when “4 GB Spanning” is set to “Off (SDXC)” (This is configurable only when “System” is set to “4K” or “High-Speed”, and when an SDXC card is used.)
- Depending on the shooting conditions, the four corners of the screen may appear dark, but this is not a malfunction. In this case, change the shooting conditions by moving the zoom lever, etc.

Capturing Still Images

Still images can be captured by tapping the  button while in the recording standby mode.



- “PHOTO” lights up on the screen when a still image is being captured.

PHOTO

Memo :

- This camera does not have a separate mode for capturing still images.
- The still image has the same resolution as the video image.

Caution :

- Still image capturing during recording standby is not possible in the following cases.
 - When the menu is displayed
 - When “System” is configured to “High-Speed”
 - When “Rec Mode” is set to “Pre Rec” or “Time-Lapse Rec”
 - When connected to Wi-Fi

Zooming

The angle of view can be adjusted using zoom.

Memorizes the zoom position while the camera is turned off.

- Use the W end (wide angle end) to shoot a wider field of view.
- Use the T end (telephoto end) to magnify the subject for shooting.

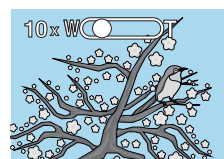

W (Wide Angle End)

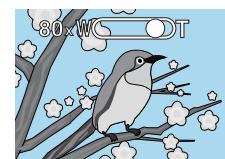
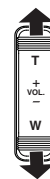

T (Telephoto End)

- The following zoom options are available:
 - When in the 4K mode
 - Optical zoom (1x to 10x)
 - Digital zoom (11x to 200x)
 - When in the HD mode
 - Optical zoom (1x to 10x)
 - Dynamic zoom (11x to 18x)
 - Digital zoom (19x to 200x)

Memo :

- When digital zoom is used, the image becomes grainy as it is digitally enlarged.
- The zoom ratio range can be changed.

“Zoom” ( p. 100)

Manual Recording

In situations where recording cannot be performed correctly in the Auto mode, it is possible to record videos with the recording mode changed to Manual.

- 1 Open the LCD monitor.

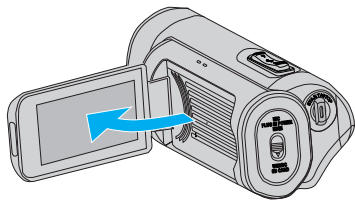

- 2 Select the Manual recording mode.



- If the camera is in the **A** mode, tap **A** to display the mode selection screen. Tap **M** to switch the recording mode to Manual.

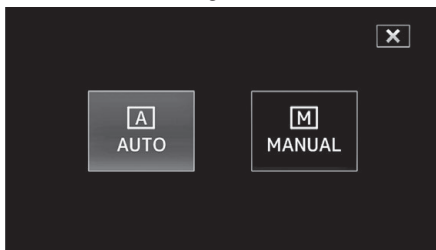

- 3 Tap "MENU".



- 4 Select "Camera Process" with \wedge or \vee , followed by tapping "SET".

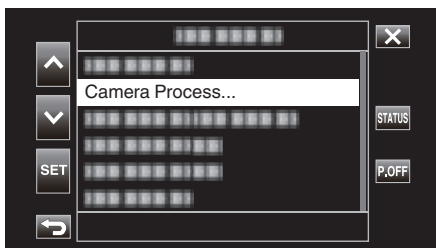

- 5 Select the desired item in the camera settings menu, followed by tapping "SET".

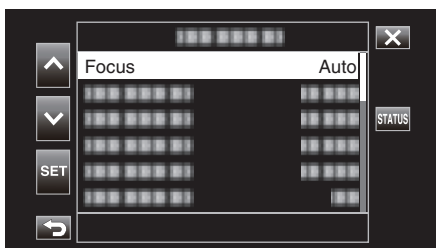

- For details on the manual settings, please refer to "Camera Setting Menu".

Camera Setting Menu

The following items can be set.

Name	Description
Focus	<ul style="list-style-type: none"> • Use manual focus if the subject is not focused automatically. "Adjusting Focus Manually (FOCUS)" (p. 23)
Brightness Adjust	<ul style="list-style-type: none"> • Overall brightness on the screen can be adjusted. • Use this when recording in a dark or bright location. "Adjusting Brightness" (p. 26)
Shutter Speed	<ul style="list-style-type: none"> • Shutter speed can be adjusted. • Use this when shooting a fast-moving subject or to emphasize the subject's movement. "Setting Shutter Speed" (p. 27)
Aperture	<ul style="list-style-type: none"> • You can adjust the aperture to capture an image with only the subject in focus while blurring the surroundings. "Setting Aperture" (p. 28)
Gain Up	<ul style="list-style-type: none"> • Automatically increases the light sensitivity when the subject is not bright enough. "Increasing the Light Sensitivity Level" (p. 29)
Backlight Comp	<ul style="list-style-type: none"> • Corrects the image when the subject appears dark due to backlight. • Use this when shooting against the light. "Setting Backlight Compensation" (p. 30)
Lolux	<ul style="list-style-type: none"> • Selects the Lolux (low-light recording) mode. "Lolux" (p. 102)
Detail	<ul style="list-style-type: none"> • Adjusts the outline enhancement level during recording. "Detail" (p. 102)
Gamma	<ul style="list-style-type: none"> • Corrects the gamma curve that determines the reproducibility of the black level. "Gamma" (p. 102)
WDR	<ul style="list-style-type: none"> • Selects the WDR mode (function for enhancing the contrast of video images by applying gradation correction to the video input). "WDR" (p. 103)
White Balance	<ul style="list-style-type: none"> • Adjusts the overall color of the image according to the light source. • Use this when the color on the screen appears differently from the actual color. "Setting White Balance" (p. 31)
Color Matrix	<ul style="list-style-type: none"> • Adjusts the color according to the user's preference using the color matrix (matrix that converts a color represented by 3 R, G and B values with another set of RGB values). "Color Matrix" (p. 103)
Reset Process	<ul style="list-style-type: none"> • Resets all the camera settings to their default values. "Reset Process" (p. 103)

Adjusting Focus Manually (FOCUS)

Adjust the focus manually when focus cannot be achieved using Auto or when you want to lock the focus.

- 1 Select the Manual recording mode.



- If the camera is in the (A) mode, tap (A) to display the mode selection screen.

Tap (M) to switch the recording mode to Manual.

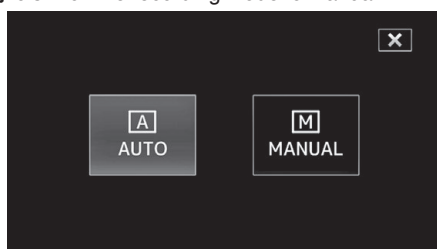

- 2 Tap "MENU".



- 3 Select "Camera Process" with ^ or v, followed by tapping "SET".

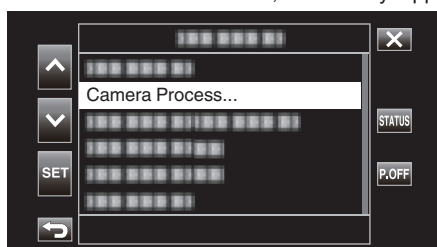

- 4 Select "Focus" with ^ or v, followed by tapping "SET".

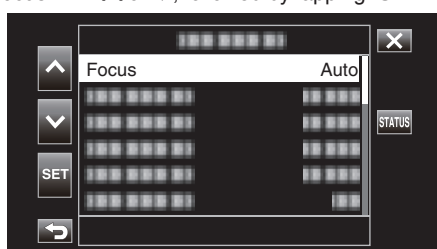

- Tap X to exit the menu.
- Tap ↶ to return to the previous screen.

- 5 Select "Manual" with ^ or v, followed by tapping "SET".

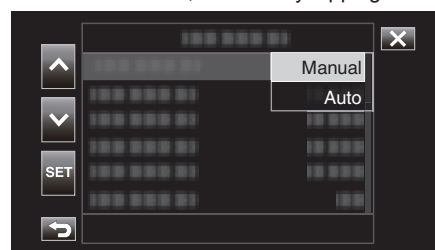

- 6 Adjust the focus.



- The manual focus icon (MF) appears on the screen.
- Tap ^ to focus on a distant subject.
- Tap v to focus on a near subject.
- Pressing and holding down the key allows focus to be adjusted continuously.

- 7 Tap "SET" to confirm.



Memo :

- This is selectable only during Manual recording.

Using the Focus Assist Function

This function switches the display temporarily to black-and-white and displays the outline of the parts of the image that are in focus in color. Adjust the focus until the part to set focus on is displayed in color. The color of the outline (multiple colors, red, green or blue) can be configured in the menu.

1 Tap "MENU".



2 Select "Monitor" with \wedge or \vee , followed by tapping "SET".

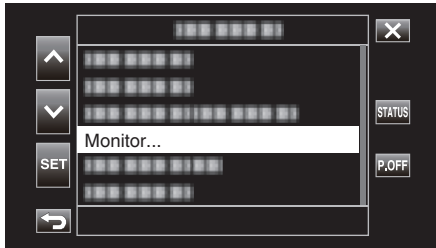

3 Select "Shooting Assist" with \wedge or \vee , followed by tapping "SET".

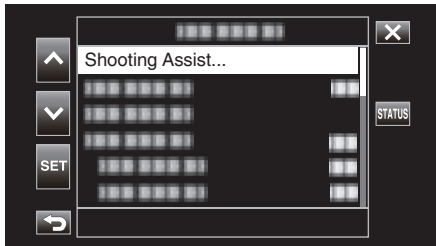

4 Select "Focus Assist" with \wedge or \vee , followed by tapping "SET".

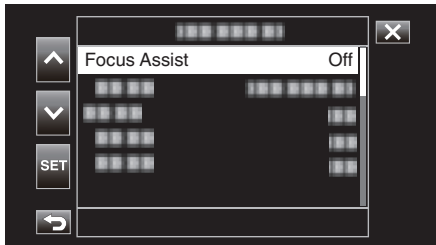

5 Select "On" with \wedge or \vee , followed by tapping "SET".

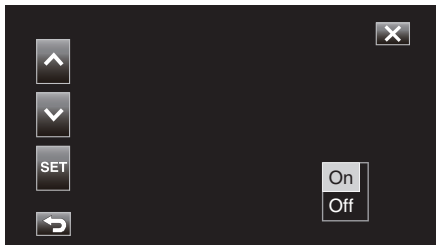

6 Select "Color" with \wedge or \vee , followed by tapping "SET".

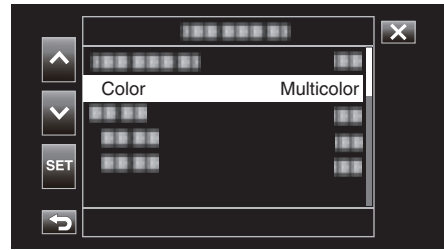

7 Select the color of the outline with \wedge or \vee , followed by tapping "SET".



Memo :

- When Focus Assist is used in a dimly-lit area, it may be difficult to identify the colored outline of areas that are grainy.
- Regardless of the "Display On TV" setting in "Video Set", Focus Assist effects cannot be output for display on a TV monitor.

Enlarging the Image (EXPANDED) for Focus Adjustment

This function enlarges the area near the center of the image. It is useful for checking or adjusting the focus.

- 1 Select the Manual recording mode.



- If the camera is in the **A** mode, tap **A** to display the mode selection screen.

Tap **M** to switch the recording mode to Manual.

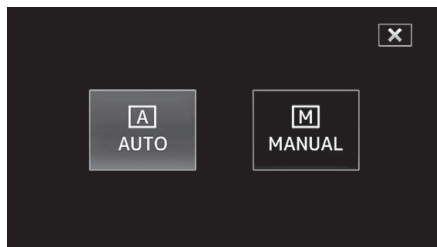

- 2 Tap "MENU".



- 3 Select "Camera Process" with \wedge or \vee , followed by tapping "SET".

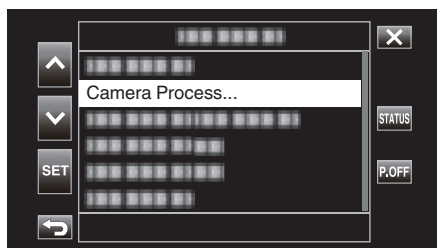

- 4 Select "Focus" with \wedge or \vee , followed by tapping "SET".

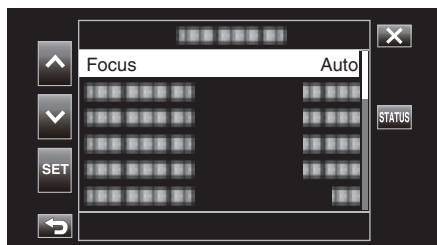

- Tap **X** to exit the menu.
- Tap \curvearrowright to return to the previous screen.

- 5 Select "Manual" with \wedge or \vee , followed by tapping "SET".

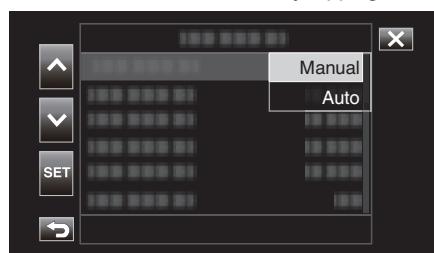

- 6 Tap \curvearrowright .



- Tap \curvearrowright to return to the previous screen.

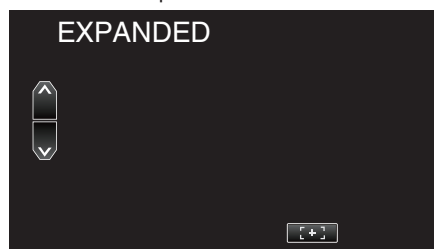

Caution :

- Only the part of the image where focus is to be adjusted manually appears enlarged.
- Images cannot be enlarged while recording is in progress.
- Recording cannot be started while in the enlarged display mode.

Memo :

- Magnifying an image does not alter the size of the recorded image.
- Images that are output to the TV do not appear enlarged.

Adjusting Brightness

You can adjust the brightness to your preferred level.

1 Select the Manual recording mode.



- If the camera is in the (A) mode, tap (A) to display the mode selection screen.

Tap (M) to switch the recording mode to Manual.

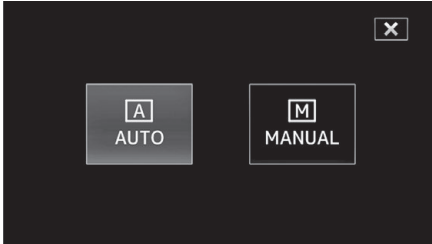

2 Tap "MENU".



3 Select "Camera Process" with ^ or v, followed by tapping "SET".

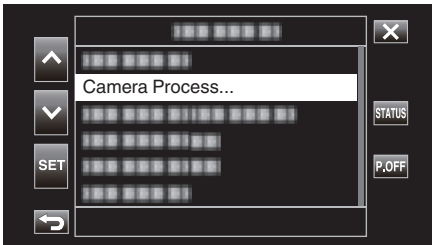

4 Select "Brightness Adjust" with ^ or v, followed by tapping "SET".

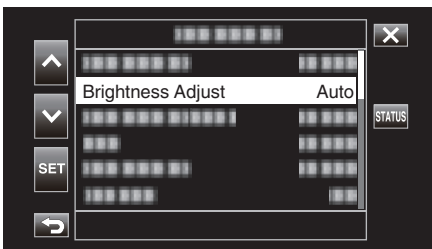

- Tap X to exit the menu.
- Tap ↶ to return to the previous screen.

5 Select "Manual" with ^ or v, followed by tapping "SET".



6 Adjust the brightness value.



- Compensation range: -6 to +6
- Tap ^ to increase the brightness.
- Tap v to decrease the brightness.
- Pressing and holding down the key allows focus to be adjusted continuously.

7 Tap "SET" to confirm.



Caution :

- Brightness Adjust cannot be selected in the following cases.
 - During Auto recording
 - When "Shutter Speed", "Aperture" and "Gain Up" are set to "Manual"
 - When "Backlight Comp" is set to "On"
 - When "Lolux" is set to "On"

Setting Shutter Speed

You can set the shutter speed to suit the type of subject.

- 1 Select the Manual recording mode.



- If the camera is in the **A** mode, tap **A** to display the mode selection screen.

Tap **M** to switch the recording mode to Manual.

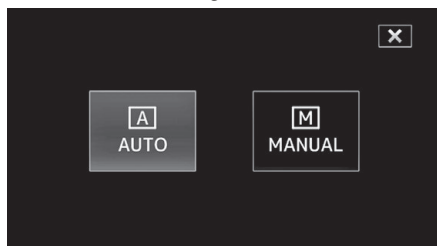

- 2 Tap "MENU".



- 3 Select "Camera Process" with \wedge or \vee , followed by tapping "SET".

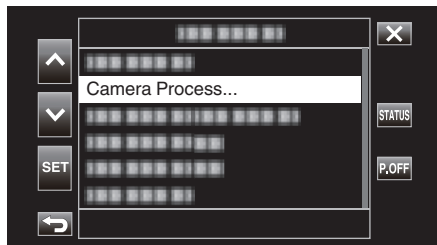

- 4 Select "Shutter Speed" with \wedge or \vee , followed by tapping "SET".

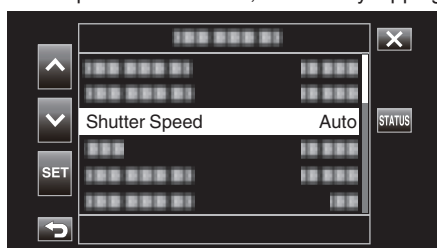

- Tap **X** to exit the menu.
- Tap \curvearrowright to return to the previous screen.

- 5 Select "Manual" with \wedge or \vee , followed by tapping "SET".

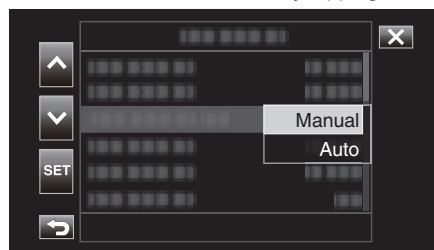

- 6 Adjust the shutter speed.



- Shutter speed can be set from 1/7.5 to 1/10000.
- Tap \wedge to increase the shutter speed.
- Tap \vee to decrease the shutter speed.
- Pressing and holding down the key allows focus to be adjusted continuously.

- 7 Tap "SET" to confirm.

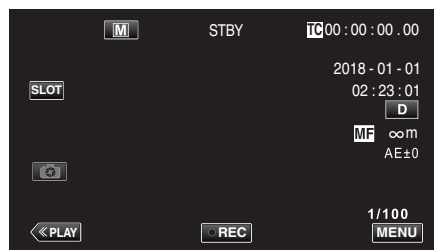

Memo :

- While fast-moving subjects can be captured clearly by increasing "Shutter Speed", the screen may appear darker. When recording in dark places such as indoors, check the brightness of the LCD monitor and set "Shutter Speed" accordingly.

Caution :

- Shutter Speed cannot be selected in the following cases.
 - During Auto recording
 - When "Lolux" is set to "On"

Recording

Setting Aperture

You can adjust the aperture to change the area of focus.

1 Select the Manual recording mode.



- If the camera is in the **A** mode, tap **A** to display the mode selection screen.
- Tap **M** to switch the recording mode to Manual.

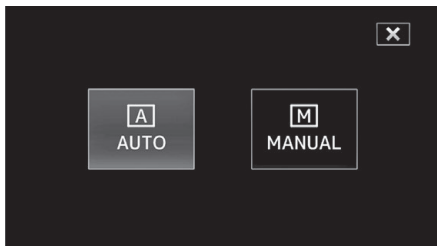

2 Tap "MENU".



3 Select "Camera Process" with ^ or v, followed by tapping "SET".

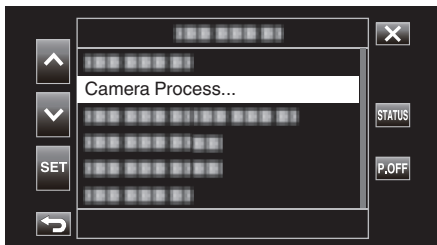

4 Select "Aperture" with ^ or v, followed by tapping "SET".

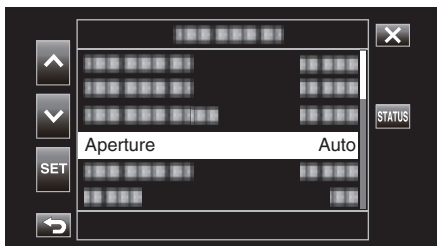

- Tap X to exit the menu.
- Tap ↶ to return to the previous screen.

5 Select "Manual" with ^ or v, followed by tapping "SET".

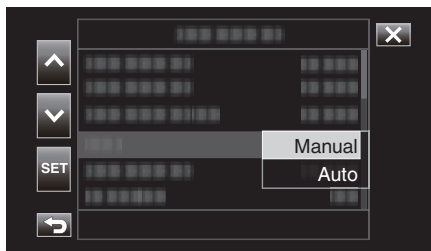

6 Adjust the aperture.



- Aperture can be set to a value between F1.8 and F4.0.
- If you want the background to be in focus as well (larger aperture value), tap v.
- If you want the background to appear blurry (smaller aperture value), tap ^.
- Pressing and holding down the key allows focus to be adjusted continuously.

7 Tap "SET" to confirm.

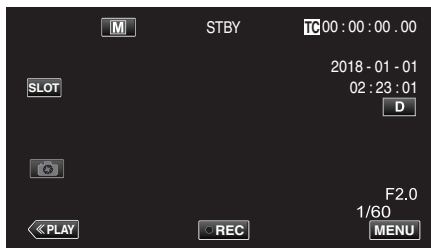

Memo :

- When zooming to the Tele end, the aperture value is set according to the zoom and indicated in yellow. The aperture value in this case will be different from the preset value.
- The larger the aperture value, the darker the subject may appear.

Caution :

- Aperture cannot be selected in the following cases.
 - During Auto recording
 - When "Lolux" is set to "On"

Increasing the Light Sensitivity Level

Automatically increases the light sensitivity when the subject is not bright enough.

1 Tap "MENU".



2 Select "Camera Process" with ^ or v, followed by tapping "SET".

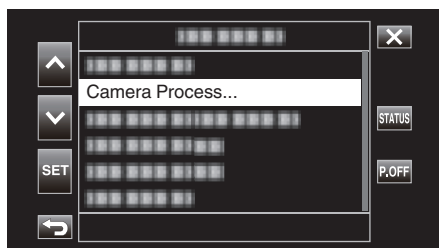

3 Select "Gain Up" with ^ or v, followed by tapping "SET".

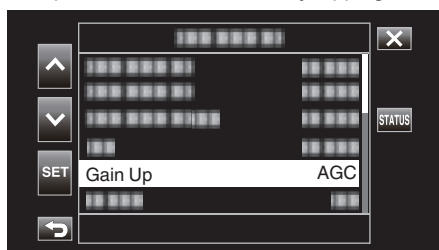

- Tap X to exit the menu.
- Tap ↶ to return to the previous screen.

4 Select the desired item with ^ or v, followed by tapping "SET".

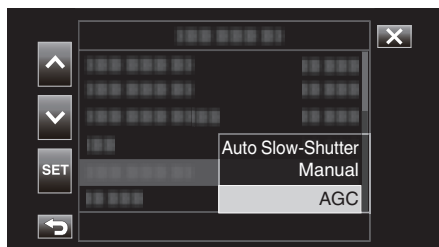

Setting	Description
Auto Slow-Shutter	Low-speed shutter that can be used to express dynamic motion. (However, it may result in blurring due to camera shake.)
Manual	Manually adjust the brightness. The brightness level can be configured to one of the following values. A larger value indicates a higher light sensitivity level. 0dB, 3dB, 6dB, 9dB, 12dB, 15dB, 18dB, 21dB, 24dB
AGC	Adjusts the brightness automatically.

<Go to Step 5 if Manual is selected>

5 Adjust the brightness to the desired level with ^ and v.



Memo :

- Increasing the light sensitivity level may cause the image to appear grainier.

6 Tap "SET" to confirm.



Caution :

- This function is not available for selection when "Lolux" is set to "On".
- "Manual" is not available for selection in the Auto Recording mode.
- This function is fixed at "AGC" in the Auto Recording mode when "System" is set to "High-Speed".
- "Auto Slow-Shutter" is not available for selection in the Manual Recording mode when "System" is set to "High-Speed".

Setting Backlight Compensation

You can correct the image when the subject appears too dark due to backlight.

1 Select the Manual recording mode.



- If the camera is in the **A** mode, tap **A** to display the mode selection screen.

Tap **M** to switch the recording mode to Manual.

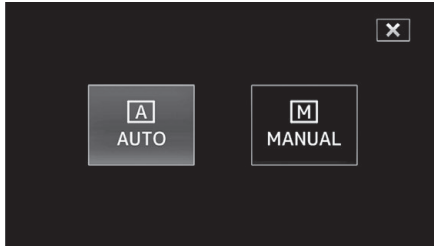

2 Tap "MENU".



3 Select "Camera Process" with \wedge or \vee , followed by tapping "SET".

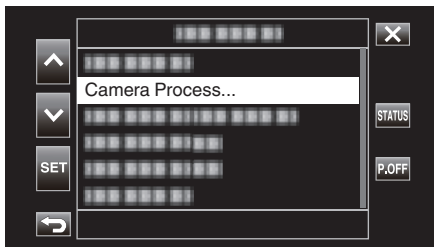

4 Select "Backlight Comp" with \wedge or \vee , followed by tapping "SET".

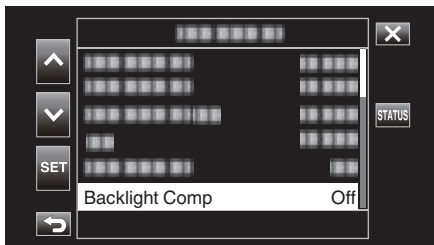

- Tap **X** to exit the menu.
- Tap \rightarrow to return to the previous screen.

5 Select "On" with \wedge or \vee , followed by tapping "SET".



Setting	Details
On	Backlight compensation is enabled.
Off	Backlight compensation is disabled.

Caution :

- Backlight Comp cannot be selected in the following cases.
 - During Auto recording
 - When "System" is set to "High-Speed"
 - When "Shutter Speed", "Aperture" and "Gain Up" are set to "Manual"
 - When "Lolux" is set to "On"

Setting White Balance

You can set the color tone to suit the light source.

- 1 Select the Manual recording mode.

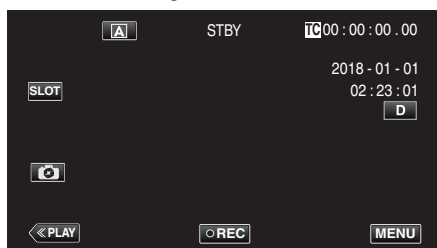

- If the camera is in the (A) mode, tap (A) to display the mode selection screen.

Tap (M) to switch the recording mode to Manual.

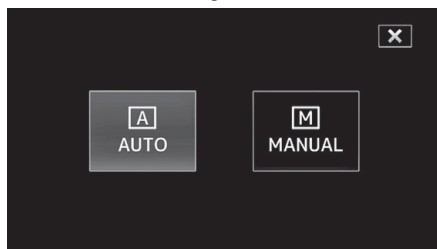

- 2 Tap "MENU".



- 3 Select "Camera Process" with ^ or v, followed by tapping "SET".

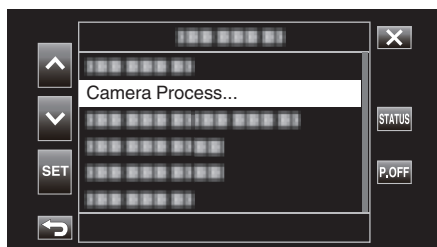

- 4 Select "White Balance" with ^ or v, followed by tapping "SET".

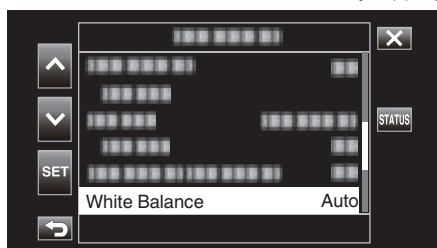

- Tap X to exit the menu.
- Tap ↶ to return to the previous screen.

- 5 Select a white balance setting with ^ or v, followed by tapping "SET".

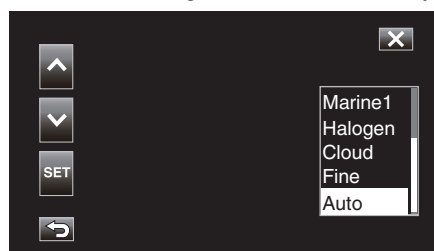

Setting	Display	Description
Auto	None	Adjusts automatically to the natural colors.
Fine	<FINE>	Set this when shooting outdoors on a sunny day.
Cloud	<CLOUD>	Set this when shooting on a cloudy day or inside a shade.
Halogen	<HALOGEN>	Set this when shooting under illumination such as a video light.
Marine1	<MARINE 1>	Set this when shooting in deep waters (water appears blue).
Marine2	<MARINE 2>	Set this when shooting in shallow waters (water appears green).
Preset	P< ****K>	Configure according to your preference.
MWB A	A< ****K>	Use this when the problem of unnatural colors is not resolved.
MWB B	B< ****K>	Use this when the problem of unnatural colors is not resolved.

(****K: Color temperature)



Recording



Using Preset

- 1 Select "Preset" with \wedge or \vee , followed by tapping "SET".
- 2 In the Camera Process menu, select "Adjust" under White Balance, followed by tapping "SET".
- 3 Select "Preset Temp." with \wedge or \vee , followed by tapping "SET".
- 4 Select an appropriate color temperature with \wedge or \vee , followed by tapping "SET".
 - To specify the settings in greater detail, display the detailed color temperature selection screen with \triangleright .
To go back to the main color temperature setting screen, tap \triangleright .

When using MWB A and MWB B

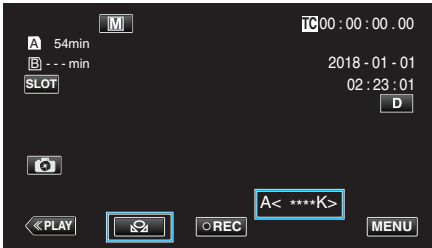
- 1 Select "MWB A" or "MWB B" with \wedge or \vee , followed by tapping "SET".
- 2 Hold a sheet of plain white paper in front of the lens so that the white paper fills the screen, followed by tapping .



- "A< " or "B< " appears on the screen during the adjustment. (The  icon starts to blink.)
- After color adjustment is complete, a rough estimation of the adjusted color temperature will be displayed.

Memo :

- Tapping  each time changes the color setting.
 - MWB A and MWB B can be configured to different colors.
-

Memo :

- This is selectable only during Manual recording.
-

Recording Data to Both Slot A and Slot B

Inserting an SD card into each of Slot A and Slot B enables “continuous recording to both SD cards” or “simultaneous recording to both SD cards”.

1 Tap “MENU”.



2 Select “System” with \wedge or \vee , followed by tapping “SET”.

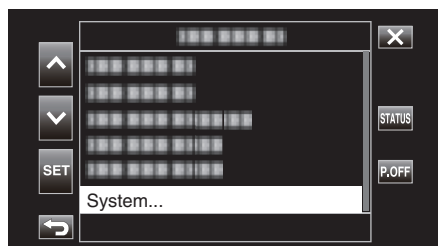

3 Select “Record Set” with \wedge or \vee , followed by tapping “SET”.

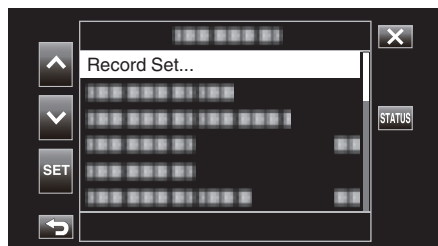

4 Select “Slot Mode” with \wedge or \vee , followed by tapping “SET”.

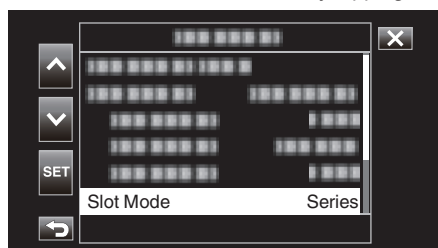

5 Select the method of recording with \wedge or \vee , followed by tapping “SET”.

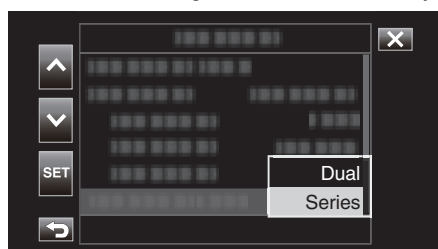

Item	Description
Dual	Records videos simultaneously to the SD cards in both slots if data can be recorded to the SD cards inserted.
Series	When recordable SD cards are inserted into both the card slots, recording starts with the card in the selected card slot. When the space on this card runs out, recording continues with the card in the other slot.

Memo :

- “Series” is configured by default.
- “DUAL” appears on the recording screen while in the Dual Rec mode.

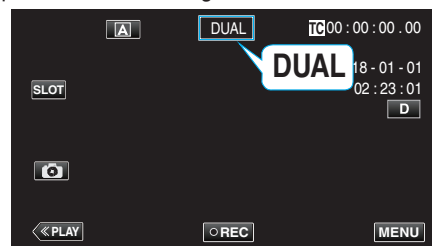

- The icons for both SD cards are lit in red while Dual Recording is in progress.
- During recording in the Dual Rec mode to two cards with a different amount of remaining space, recording to both slots will stop automatically if the space on one card runs out. After recording stops, recording automatically resumes for the card with remaining space.
- If the last recorded file on the SD cards that are inserted in the two slots are different from each other, and “TC Generator” is set to “Regen”, the Regen mode for the selected card slot will be enabled in the next recording.

Caution :

- When “System” is set to “4K” or “High-Speed”, Dual Recording cannot be configured.
- To perform recording in the Dual Rec mode, it is recommended that this be done using two formatted SD cards with the same capacity.
- Dual Recording can be used concurrently with the Special Effect Recording mode. Even while the camera is in the Dual Rec mode, it is possible to configure “Rec Mode” to “Normal”, “Pre Rec”, “Scene Continuous”, or “Time-Lapse Rec”.
- Dual Recording (simultaneous recording) can be performed when both slots are inserted with recordable SD cards. If a recordable SD card is only inserted in one of the slots, it is possible to start recording with one card.
- In the Dual Rec mode, it is not possible to continue recording by switching from the card in one slot to that in the other slot. Continuous recording will not be performed if a recordable SD card is inserted into a slot after recording to the card in the other slot has started.
- If recording to one slot is in progress when the camera is configured to the Dual Rec mode, inserting a recordable media to the other slot does not enable the Dual Recording operation. To perform the Dual Recording operation, stop recording (excluding pausing recording in the Continuous Scene Rec mode) and start again.
- When one of the SD cards is accidentally removed while recording is in progress in the Dual Rec mode, recording to the card in the other slot will continue. However, it may not be possible to repair the accidentally removed card with the recovery function.
- If an error occurs on one of the cards while recording is in progress in the Dual Rec mode, recording to the malfunctioning card stops, while that to the other card continues.
- Operations such as deleting and protecting scenes of videos recorded in the Dual Rec mode can only be performed on the SD card in the selected slot.

Slow-motion (High-speed) Recording

You can record videos in slow-motion by increasing the recording speed to emphasize the movements, and play back the slow-motion video smoothly. Playing back casual scenes in slow motion helps to add a dramatic effect.

Item	Value
Recording Speed	100 fps, 50 fps, 120 fps, 60 fps
Image Size	1920×1080
Bit rate	16 Mbps

- The playback time will be 2 or 4 times of the actual recorded time. (Example: If the recorded time is 1 minute, the playback time will be 2 or 4 minutes.)

1 Tap "MENU".



2 Select "System" with ^ or v, followed by tapping "SET".

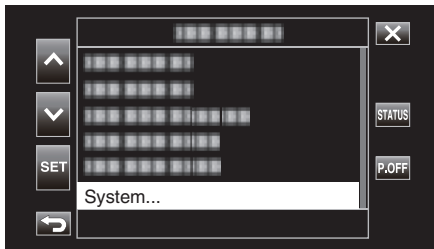

3 Select "Record Set" with ^ or v, followed by tapping "SET".

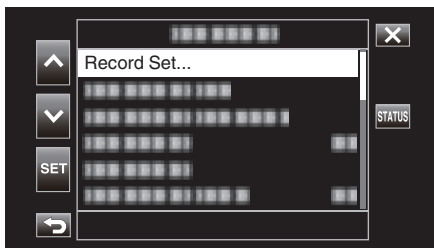

4 Select "Record Format" with ^ or v, followed by tapping "SET".

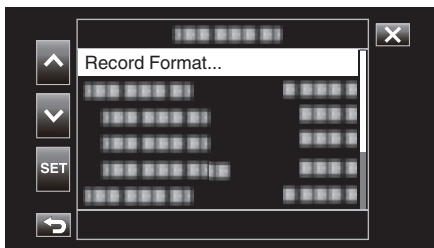

5 Select "System" with ^ or v, followed by tapping "SET".

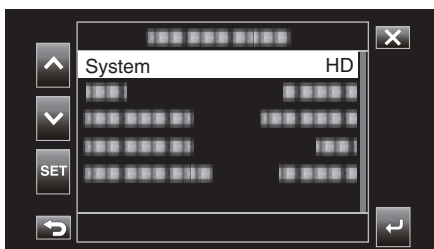

6 Select "High-Speed" with ^ or v, followed by tapping "SET".

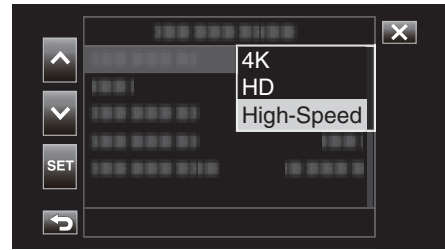

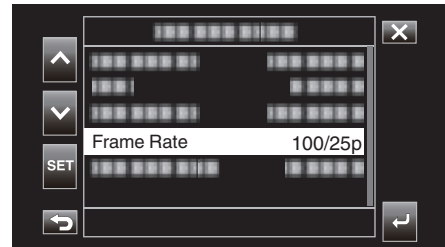

7 Select "Frame Rate" with ^ or v, followed by tapping "SET".

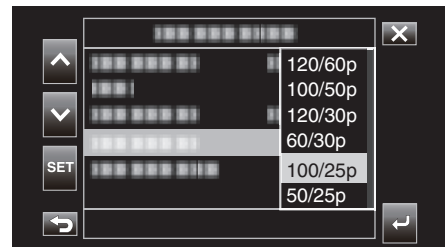

8 Select the recording speed with ^ or v, followed by tapping "SET".



Item	Description
120/60p	Records at 120 fps with a playback time that is 2 times longer. (Example) The playback time of a 1 minute video will be 2 minutes.
100/50p	Records at 100 fps with a playback time that is 2 times longer. (Example) The playback time of a 1 minute video will be 2 minutes.
120/30p	Records at 120 fps with a playback time that is 4 times longer. (Example) The playback time of a 1 minute video will be 4 minutes.
100/25p	Records at 100 fps with a playback time that is 4 times longer. (Example) The playback time of a 1 minute video will be 4 minutes.
60/30p	Records at 60 fps with a playback time that is 2 times longer. (Example) The playback time of a 1 minute video will be 2 minutes.
50/25p	Records at 50 fps with a playback time that is 2 times longer. (Example) The playback time of a 1 minute video will be 2 minutes.

9 Tap  or .

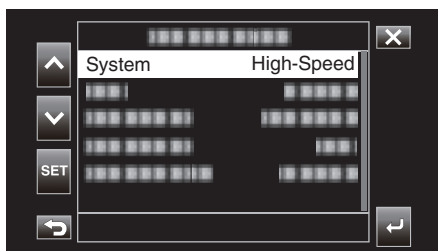

10 Select "Apply" with  or , followed by tapping "SET".

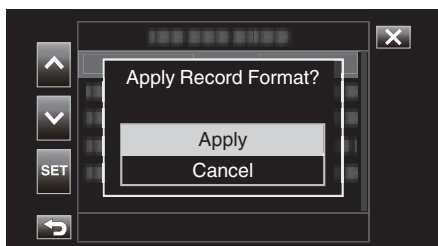

Memo :

- Fixes the recording mode at Normal.
- Images may appear grainier than other videos. It is recommended that the subject be captured in a size that is as big as possible. The image displayed on the LCD monitor during recording may also appear grainier.
- Audio will not be recorded.
- When high-speed recording is enabled, only the optical zoom can be used.
- During high-speed recording, "Touch Priority AE/AF" is set to "Off". In addition, as "DIS" is set to "Off", it is recommended that a tripod be used, and recording be performed at a bright location.

"Tripod Mounting" (📖 p. 15)

- Only "Rec Run" or "Regen" can be selected for "TC Generator".
- It is not possible to configure a shutter speed that is slower than the frame rate setting.
(Example: When the frame rate setting is 100/50p, the shutter speed can be configured to a value between 1/100 and 1/10000.)
- The media remaining indication displays the total playback time when playing back the scenes recorded before the remaining space on the media becomes "0".
- The remaining space on the media will decrease at a faster rate than usual.
(Example: As recording is performed at a speed that is 2 times slower than usual at 100/50p, the remaining space on the media will decrease at a rate that is about 2 times faster.)
- The screen may darken for 5 to 6 seconds when the recording format setting is changed.

Shooting under Water

Perform the following settings to shoot underwater.

Setting the White Balance to Underwater Mode

Corrects the color when shooting underwater to record more natural images. Select from the following two settings depending on the color of the water at the shooting location.

1 Select the Manual recording mode.



- If the camera is in the **A** mode, tap **A** to display the mode selection screen. Tap **M** to switch the recording mode to Manual.

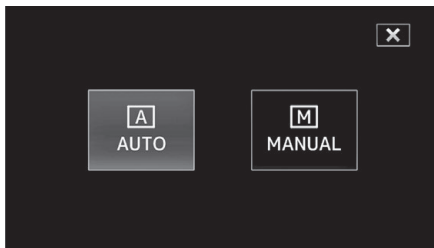

2 Tap "MENU".



3 Select "Camera Process" with \wedge or \vee , followed by tapping "SET".

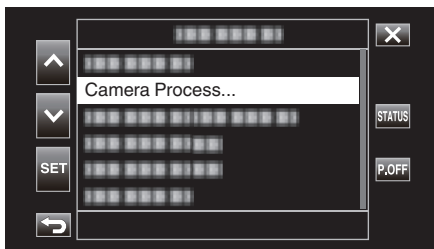

4 Select "White Balance" with \wedge or \vee , followed by tapping "SET".

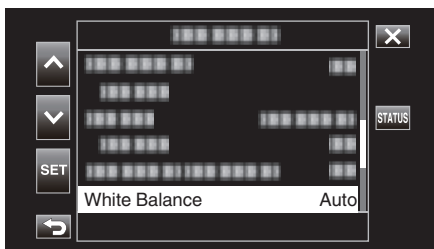

5 Select "Marine1" or "Marine2" with \wedge or \vee , followed by tapping "SET".

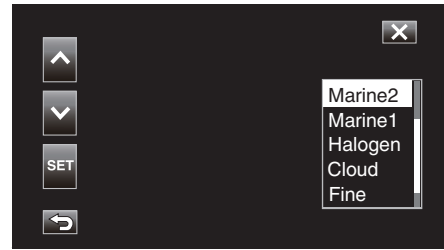

Setting	Display	Description
Marine1	<MARINE 1>	Set this when shooting in deep waters (water appears blue).
Marine2	<MARINE 2>	Set this when shooting in shallow waters (water appears green).

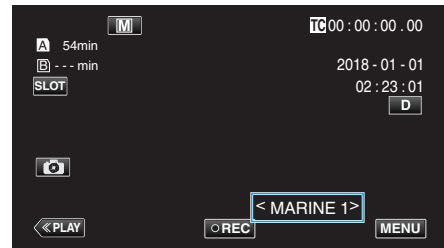

Memo :

- You may not necessarily achieve the correction effect as expected.
- It is recommended to conduct a trial recording in advance.

Locking the Screen

- 1 Tap "MENU".



- 2 Select "System" with \wedge or \vee , followed by tapping "SET".

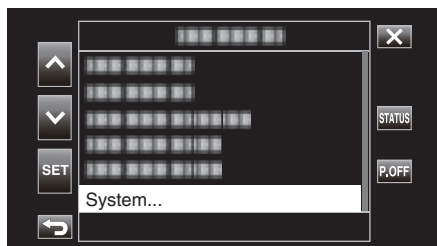

- 3 Select "Screen Lock" with \wedge or \vee , followed by tapping "SET".

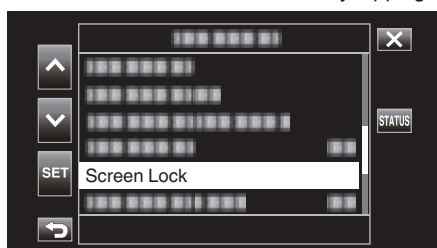

- The  button appears.

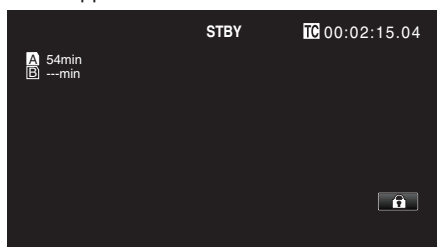

■ To Cancel "Screen Lock"

Tap the  button.



Memo :

- Once "Screen Lock" is set, only the  button on the touch screen can be operated.
- The START/STOP (recording) button and the zoom lever can be used while the screen is locked.
- "Screen Lock" cannot be set for the following cases:
 - During recording
 - When "System" is set to "High-Speed"
 - When "Time-Lapse Rec" is configured
 - When connected to Wi-Fi

Caution :

- Before using the camera underwater, read "Before Using Underwater or under Low Temperature" (p. 18) carefully. Improper usage resulting in water submersion will damage the device and cause injury.
- Ensure that the terminal cover is closed tightly before using underwater or on the beach.
"Opening the Terminal Cover (SD Card Cover)" (p. 5)

Capturing Subjects Clearly (TOUCH PRIORITY AE/AF)

“Touch Priority AE/AF” is a function that adjusts focus and brightness based on a tapped position.

1 Tap “MENU”.



2 Select “Camera Function” with ^ or v, followed by tapping “SET”.

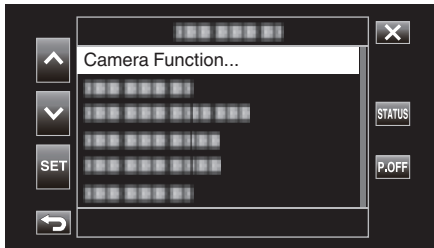

3 Select “Touch Priority AE/AF” with ^ or v, followed by tapping “SET”.

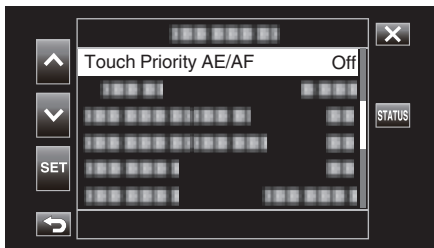

- Tap X to exit the menu.
- Tap ↶ to return to the previous screen.

4 Select the desired item, followed by tapping “SET”.

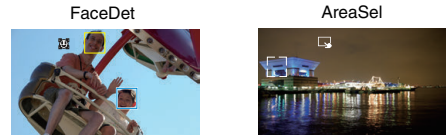
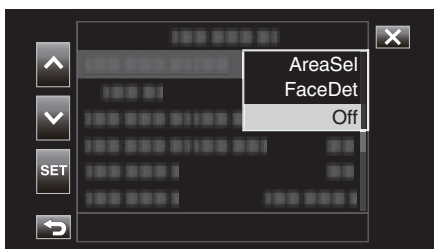

- Focus and brightness will be adjusted automatically based on the tapped position (face/area). A blue frame appears around the selected subject (face), while a white frame appears around the selected area.
- To reconfigure, tap the desired position (face/area) again.
- To cancel “AreaSel”, tap the white frame.

Setting	Details
AreaSel	☞ appears on the screen. Recording is performed while automatically adjusting the tapped area (fixed position) with appropriate focus and brightness. In addition, a white frame appears around the tapped area. AreaSel in Touch Priority AE/AF is only available within the optical zoom range. (Disabled when digital zoom is operating)
FaceDet	☞ appears on the screen. A yellow frame appears around the detected face (subject), which turns into blue color when it is tapped. Doing so performs recording by automatically adjusting the focus and brightness based on those of the subject. AF & AE: Adjusts both the focus and brightness automatically for the face that is being tracked. AF: Adjusts the focus automatically for the face that is being tracked.
Off	Deactivates the function.

Memo :

- When “Touch Priority AE/AF” is set, “Focus” will be set to “Auto” automatically.
- Settings are canceled when zoom operation is performed. (“AreaSel” only)

Caution :

- Subjects near the sides of the LCD monitor may not respond or be recognized when tapped. In this case, move the subject to the center and tap again.
- “AreaSel” is not available while the digital zoom is in use.
- Touch Priority AE/AF cannot be selected in the following cases.
 - When “Focus” is set to “Manual”
 - When “System” is set to “High-Speed”
 - When “Rec Mode” is set to “Time-Lapse Rec”
- When all of “Shutter Speed”, “Aperture” and “Gain Up” are set to “Manual”, “AreaSel” cannot be selected.
- FaceDet cannot be selected in the following cases.
 - When “Backlight Comp” is set to “On”
 - When “Lolux” is set to “On”

Reducing Camera Shake

When the image stabilizer is set, camera shake during video recording can be effectively reduced.

The following are the steps when “System” is set to “HD”.

- 1 Tap “MENU”.



- 2 Select “Camera Function” with \wedge or \vee , followed by tapping “SET”.

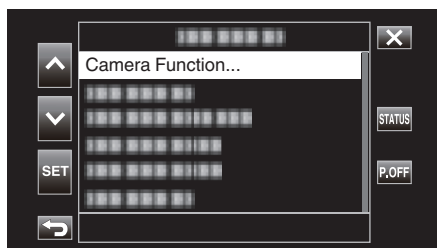

- 3 Select “DIS” with \wedge or \vee , followed by tapping “SET”.

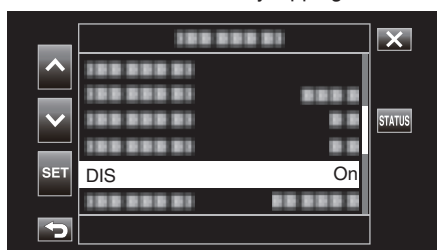

- Tap \times to exit the menu.
- Tap \curvearrowright to return to the previous screen.

- 4 Select the desired item, followed by tapping “SET”.

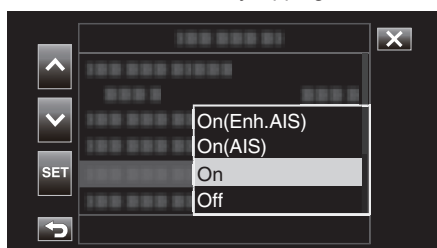

■ When “System” is set to “4K”

Setting	Details
Off	Deactivates image stabilizer.
On	Reduces camera shake under normal shooting conditions.

■ When “System” is set to “HD”

Setting	Details
Off	Deactivates image stabilizer.
On	Reduces camera shake under normal shooting conditions.
On(AIS)	Reduces camera shake more effectively when shooting bright scenes on the wide angle end. Only on the wide angle end (approx. 5x).
On(Enh.AIS)	The area of correction in the enhanced AIS mode is greater than that in the AIS mode. Camera shake can be reduced more effectively even when recording is performed by zooming from wide angle to telephoto.

■ When “System” is set to “High-Speed”

Fixed at “Off”.

Memo :

- It is recommended to set the image stabilizer to “Off” when shooting a subject of little movement with the unit on a tripod.
- Complete stabilization may not be possible if camera shake is excessive.
- Using the image stabilizer will narrow the angle of view.

Caution :

- Image stabilization cannot be selected in the following cases.
 - During recording
 - When “System” is set to “High-Speed”
 - When “Rec Mode” is set to “Pre Rec” or “Time-Lapse Rec”
 - When “Live Streaming” is set to “On”

Taking Close-up Shots (TELE MACRO)

You can take close-up shots of an object using the tele macro function even when the unit is at the telephoto zoom setting.



*The image is only an impression.

1 Select the Manual recording mode.



- If the camera is in the (A) mode, tap (A) to display the mode selection screen. Tap (M) to switch the recording mode to Manual.

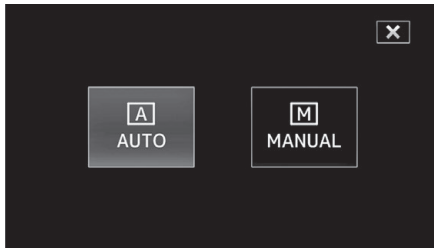

2 Tap "MENU".



3 Select "Camera Function" with ^ or v, followed by tapping "SET".

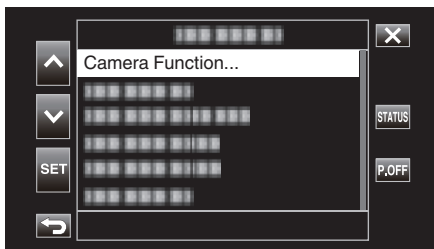

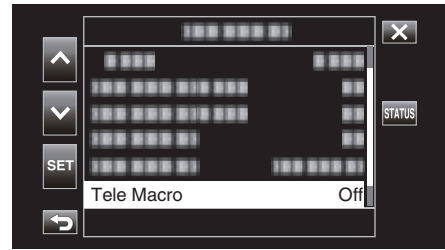

4 Select "Tele Macro" with ^ or v, followed by tapping "SET".

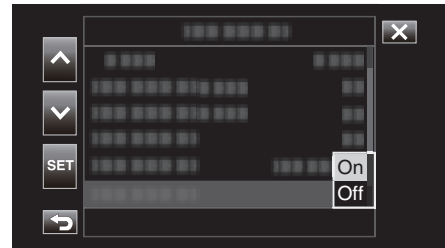

- Tap X to exit the menu.
- Tap ↶ to return to the previous screen.

5 Select "On" with ^ or v, followed by tapping "SET".



- After setting, the tele macro icon  appears.

Setting	Details
Off	Enables close-up shots up to 1 m at the telephoto (T) end. Enables close-up shots up to 5 cm at the wide angle (W) end.
On	Enables close-up shots up to 60 cm at the telephoto (T) end. Enables close-up shots up to 5 cm at the wide angle (W) end.

Memo :

- This is selectable only during Manual recording.

Caution :

- When you are not taking close-up shots, set "Tele Macro" to "Off". Otherwise, the image may be blur.

Special Effect Recording

Time-lapse Recording (Time-Lapse Rec)

This function enables the changes of a scene that occur slowly over a long period to be shown within a short time by taking frames of it at a certain interval.

This is useful for making observations such as the opening of a flower bud.

1 Tap "MENU".



2 Select "System" with \wedge or \vee , followed by tapping "SET".

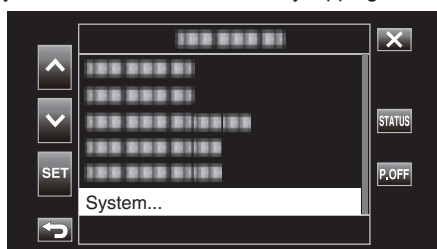

3 Select "Record Set" with \wedge or \vee , followed by tapping "SET".

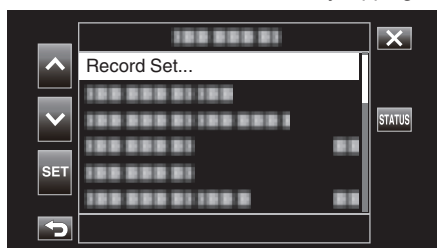

4 Select "Rec Mode" with \wedge or \vee , followed by tapping "SET".

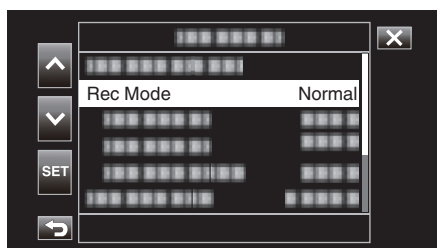

5 Select "Time-Lapse Rec" with \wedge or \vee , followed by tapping "SET".

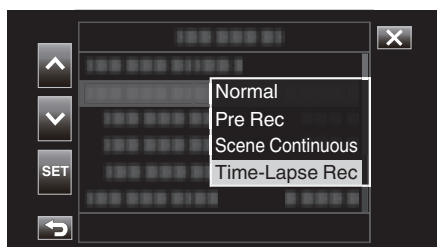

- Tap X to exit the menu.
- Tap \curvearrowright to return to the previous screen.

6 Select "Rec Frames" with \wedge or \vee , followed by tapping "SET".

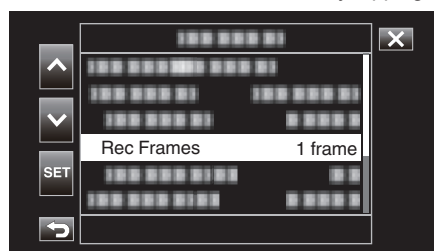

- Records according to the preset number of frames.

7 Select Rec Frames with \wedge or \vee , followed by tapping "SET".

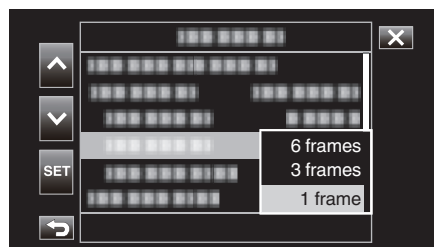

8 Select "Rec Interval" with \wedge or \vee , followed by tapping "SET".

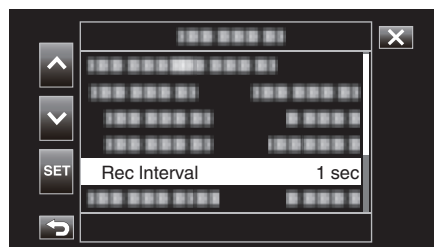

9 Select Rec Interval with \wedge or \vee , followed by tapping "SET".

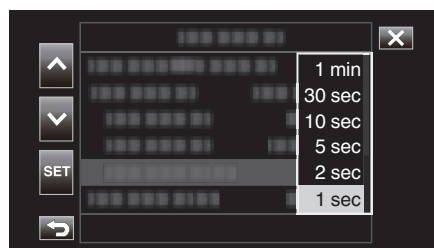

- The greater the number of seconds, the longer the recording interval.

10 Tap X to exit the menu.

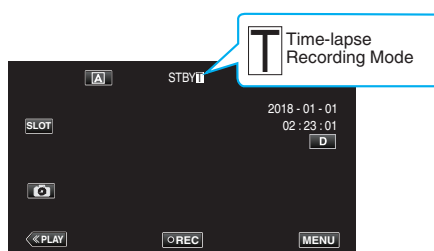

11 Start recording.

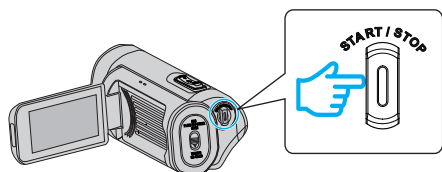

- Records based on the preset recording interval and number of frames.

Item	Setting Value
Rec Frames	1 frame, 3 frames, 6 frames
Rec Interval	1 sec, 2 sec, 5 sec, 10 sec, 30 sec, 1 min, 2 min, 5 min, 10 min, 30 min, 1 hour

- The display changes as follows: **STBY** → **●REC** → **STBY** (red text) → **●REC** → **STBY** (red text) ...

Caution :

- Do not remove the SD card during recording (**●REC**, red text) or while recording is paused (**STBY**, red text).
- Audio cannot be recorded with the video during time-lapse recording.
- If the recorded scenes do not reach a specified amount when recording is stopped, normal recording is performed and scenes are added to the end of the clip until the amount is reached.
- Simultaneous still image recording and image stabilizer are not usable when time-lapse recording is enabled.
- When time-lapse recording is enabled, "TC Generator" cannot be set to "Free Run".
- Unavailable when "System" is set to "High-Speed".
- Time-Lapse Rec will be canceled when the power is turned off. "Rec Mode" will be restored to "Normal".
If "Quick Restart" is set to "On", the camera will also return to "Normal" recording mode when the LCD monitor is closed.

Memo :

- Make use of a tripod and AC adapter for time-lapse recordings with long intervals.

It is also recommended to fix the focus and white balance manually.

"Tripod Mounting" (☞ p. 15)

Pre Rec

“Pre Rec Time” can be used to specify the number of seconds for video and audio to be recorded before the actual recording starts. Using Pre Rec enables recording of a complete event without missing the initial scenes even when you start the recording late.

Resulting File
(Recorded video and audio)

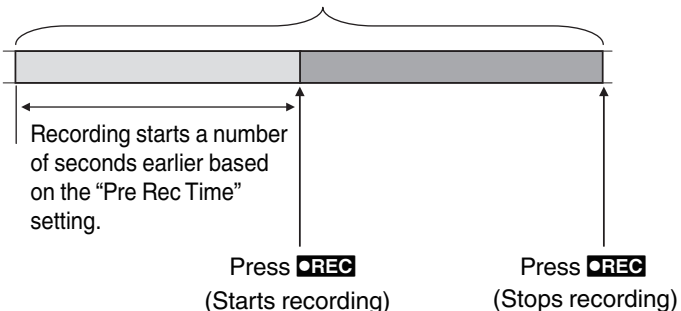

1 Tap “MENU”.



2 Select “System” with ^ or v, followed by tapping “SET”.

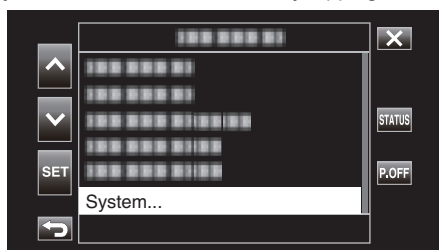

3 Select “Record Set” with ^ or v, followed by tapping “SET”.

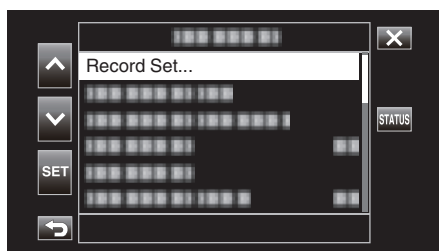

4 Select “Rec Mode” with ^ or v, followed by tapping “SET”.

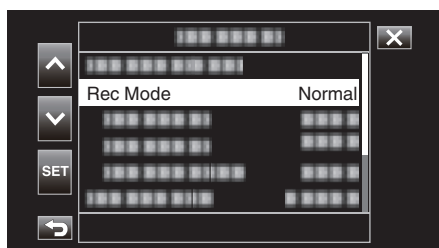

5 Select “Pre Rec” with ^ or v, followed by tapping “SET”.

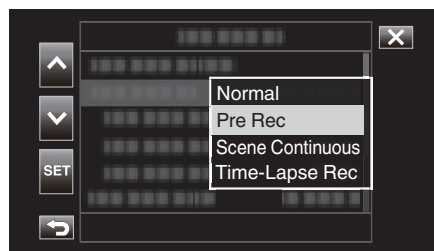

- Tap X to exit the menu.
- Tap ↶ to return to the previous screen.

6 Select “Pre Rec Time” with ^ or v, followed by tapping “SET”.

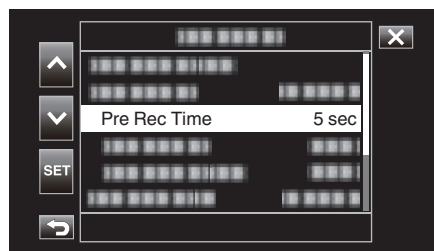

7 Select a setting value with ^ or v, followed by tapping “SET”.

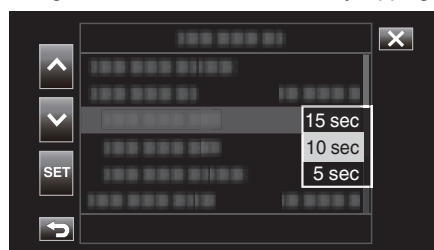

8 Tap X to exit the menu.

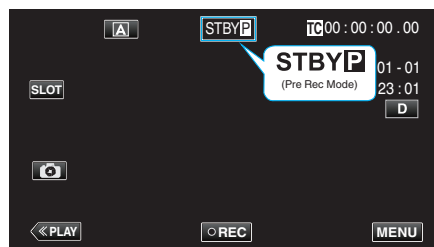

Memo :

- This is fixed at “5 sec” when “System” is set to “4K”.
- Pre-recording will not be performed during the preconfigured interval in “Pre Rec Time” if the time interval after the power of the camera is turned on or after switching from the Playback mode to the Recording mode up to the time when recording starts is shorter than the duration configured here.
- Operation sound is muted in Pre Rec mode.

Caution :

- In the following cases, video and audio during the specified Pre Rec time may not be recorded when the actual recording starts.
 - Starting recording immediately after recording stops
 - Immediately after configuring “Rec Mode”
- Unavailable when “System” is set to “High-Speed”.
- “Pre Rec” will be canceled when the power is turned off. “Rec Mode” will be restored to “Normal”. If “Quick Restart” is set to “On”, the camera will also return to “Normal” recording mode when the LCD monitor is closed.

Setting	Description
15 sec	Records video and audio 15 seconds before actual recording starts.
10 sec	Records video and audio 10 seconds before actual recording starts.
5 sec	Records video and audio 5 seconds before actual recording starts.

Scene Continuous

During normal recording, the image, audio and accompanying data from the start till the end of the recording are recorded as a single file when recording stops. Scene Continuous enables several rounds of recordings (from the time when recording starts to the time when it is stopped) to be consolidated into a single file.

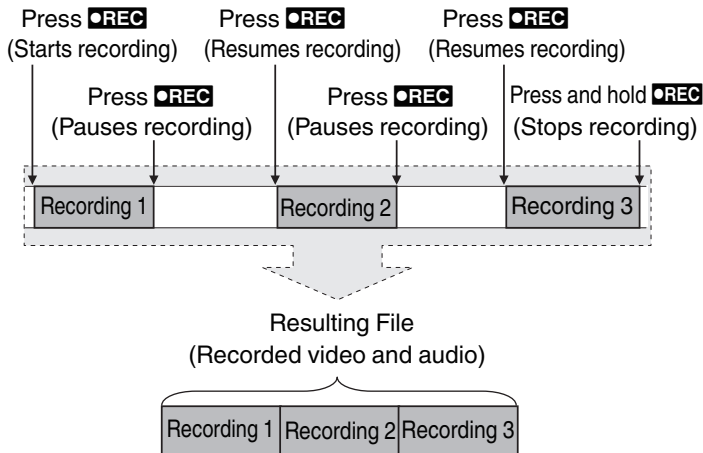

1 Tap "MENU".



2 Select "System" with \wedge or \vee , followed by tapping "SET".

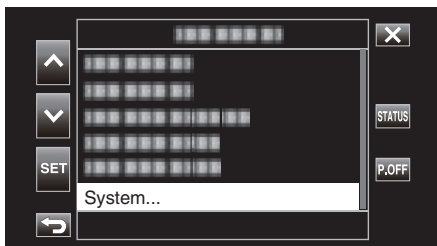

3 Select "Record Set" with \wedge or \vee , followed by tapping "SET".

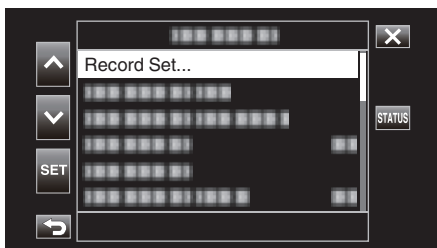

4 Select "Rec Mode" with \wedge or \vee , followed by tapping "SET".

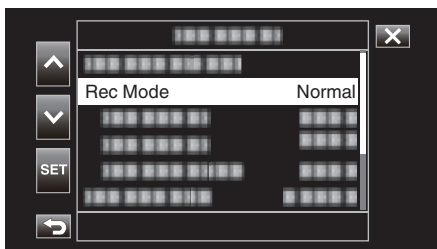

5 Select "Scene Continuous" with \wedge or \vee , followed by tapping "SET".

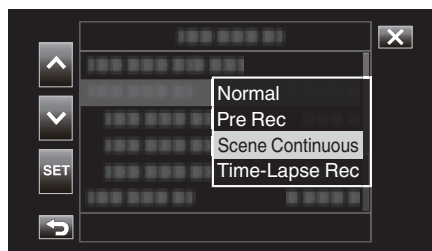

6 Tap X to exit the menu.

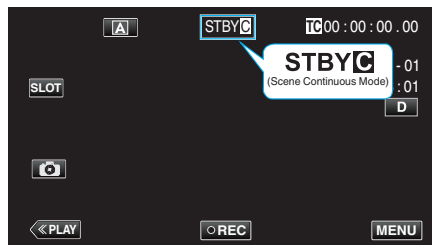

- Tap X to exit the menu.
- Tap \rightarrow to return to the previous screen.

7 Start recording (Recording 1).

- Displayed on screen: **REC**

8 Pause recording.

- Displayed on screen: **STBY** (yellow text)

9 Resume recording (Recording 2).

- Displayed on screen: **REC**

10 Pause recording.

- Displayed on screen: **STBY** (yellow text)

11 Resume recording (Recording 3).

- Displayed on screen: **REC**

12 Press and hold **REC**.

- Stops recording.
- Displayed on screen: **STBY** (white text)

Memo :

- Switching of the SD card slot is disabled when recording is paused.

Caution :

- Unavailable when "System" is set to "High-Speed".
- Do not remove the SD card during recording or while recording is paused.
- Recording stops if the remaining space on the SD card runs out during recording.
- If the power is cut off due to low battery power, a proper file may not be generated.
- "Scene Continuous" will be canceled when the power is turned off. "Rec Mode" will be restored to "Normal".
If "Quick Restart" is set to "On", the camera will also return to "Normal" recording mode when the LCD monitor is closed.

Using the Self-timer

You can record video or still image using the self-timer.

This is useful when taking a video or still image that includes the photographer.

The 2-second self-timer is useful for preventing camera shake caused by pressing the shutter button when taking a still image.

Memo :

- When shooting a photo using the self-timer function, use of a tripod is recommended.

“Tripod Mounting” (p. 15)

Using Video Self Timer

- 1 Tap “MENU”.



- 2 Select “Camera Function” with \wedge or \vee , followed by tapping “SET”.

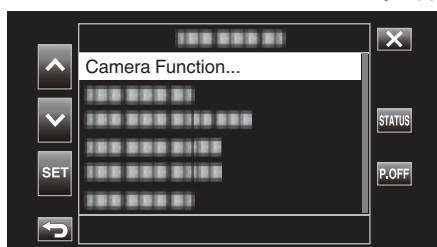

- 3 Select “Video Self Timer” with \wedge or \vee , followed by tapping “SET”.

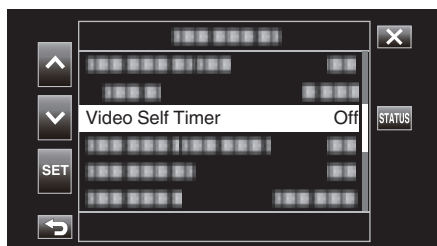

- Tap X to exit the menu.
- Tap \curvearrowright to return to the previous screen.

- 4 Select “On” with \wedge or \vee , followed by tapping “SET”.

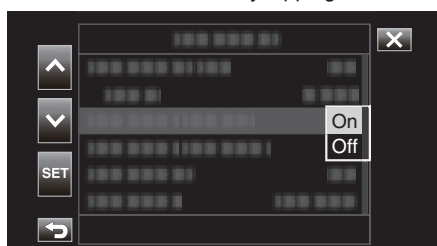

- 5 Press the START/STOP button.

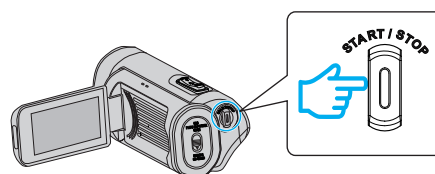

- The countdown to recording appears and recording will start after 5 seconds.
- To stop the self-timer, press the recording button again.

Caution :

- The “Video Self Timer” setting cannot be changed in the following cases.
 - During recording
 - When “Rec Mode” is set to “Pre Rec” or “Time-Lapse Rec”
- Also, the self-timer function is disabled when “Rec Mode” is set to “Pre Rec” or “Time-Lapse Rec”.

Recording

■ Using Still Self Timer

1 Tap "MENU".



2 Select "Camera Function" with \wedge or \vee , followed by tapping "SET".

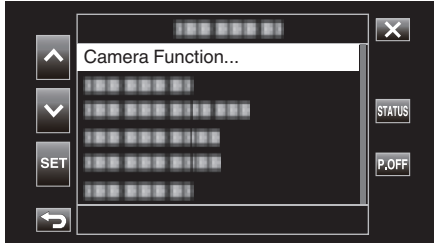

3 Select "Still Self Timer" with \wedge or \vee , followed by tapping "SET".

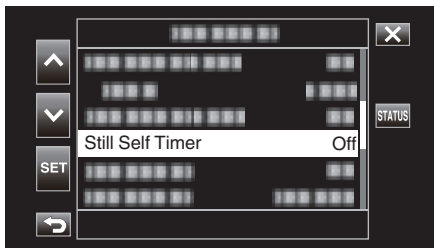

- Tap X to exit the menu.
- Tap \rightarrow to return to the previous screen.

4 Select "2sec" or "10sec" with \wedge or \vee , followed by tapping "SET".

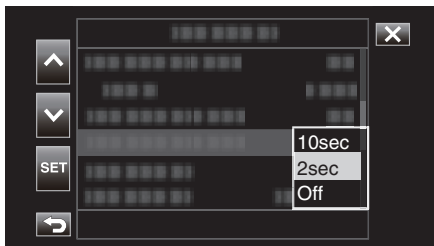

5 Tap  to take a shot.



- A timer appears and countdown to shooting starts.

Caution :

- The "Still Self Timer" setting cannot be changed in the following cases.
 - During recording
 - When "System" is set to "High-Speed"
 - When "Rec Mode" is set to "Pre Rec" or "Time-Lapse Rec"

Memo :

- While the countdown timer is displayed, the buttons cannot be used as they are not displayed on the screen.

Changing the Mode of Time Code (TC) Recording

The time code data is recorded together with the video. The time code is displayed on the LCD monitor screen during playback or recording.

1 Tap "MENU".



2 Select "TC" with \wedge or \vee , followed by tapping "SET".

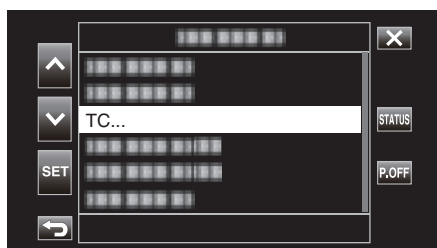

3 Select "TC Generator" with \wedge or \vee , followed by tapping "SET".

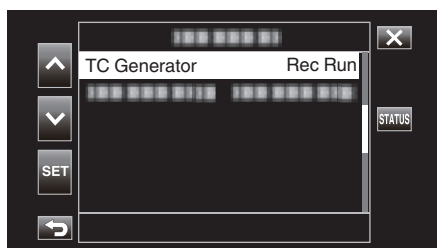

4 Select a setting value with \wedge or \vee , followed by tapping "SET".

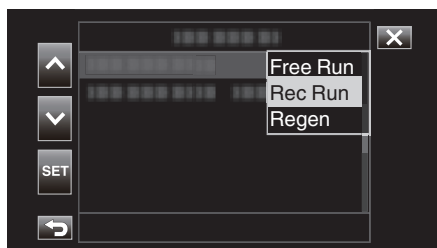

5 Start recording.

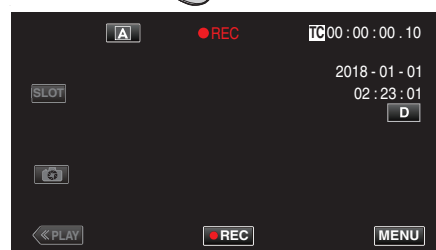
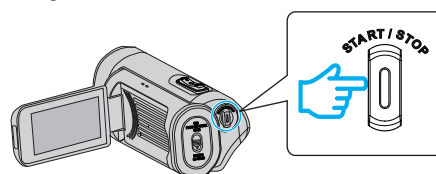

• Press the START/STOP button again to stop recording.

Setting	Description
Free Run	The time code advances at all times regardless of the recording status. The time code advances even when this unit is turned off.
Rec Run	The time code advances only when recording is in progress. It continues to run in the order of the recorded scenes as long as the SD card is not replaced. If the SD card is removed and recording is made on another card, time code will be recorded on the new card from where it was left off in the previous card.
Regen	The time code advances only when recording is in progress. When the SD card is replaced, the last time code recorded on the card is read and recorded on a new card so that the time code continues in running order.

Memo :

- When "Rec Mode" is set to "Time-Lapse Rec" and "TC Generator" to "Free Run", the Rec Run mode is activated.
- When "System" is set to "HD" and "Rec Mode" to "Pre Rec", the Free Run mode is activated.

Checking the Remaining Battery Level and Recording Time

Display the remaining battery power and the remaining recording time.

Memo : _____

- The remaining battery power and the remaining recording time are estimates.

Recording Mode

1 Tap "MENU".



2 Select "Monitor" with \wedge or \vee , followed by tapping "SET".

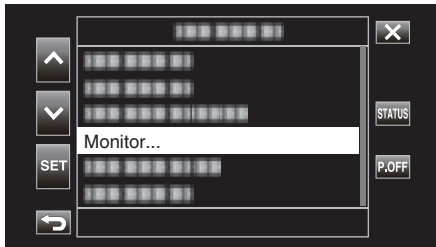

3 Select "Display Settings" with \wedge or \vee , followed by tapping "SET".

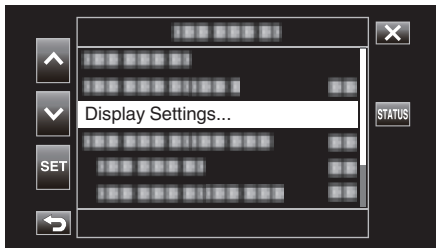

4 Select "Media Remain" or "Battery" with \wedge or \vee , followed by tapping "SET".

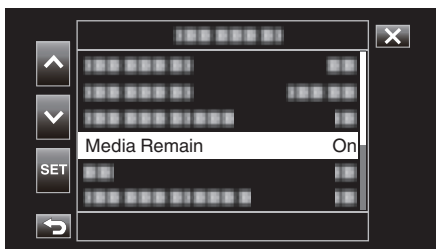

5 Select "On" with \wedge or \vee , followed by tapping "SET".

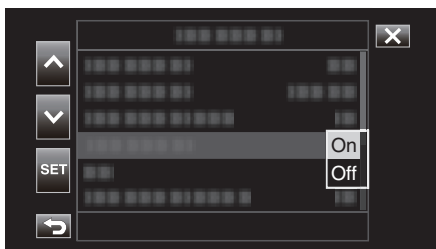

- To exit the menu, tap X.

Remaining Recording Time, Battery Level



- The white SD card icon indicates the slot that is currently selected.
- When the battery level is running low, the battery icon and the battery level indicator changes to the following colors.
 - When battery level is 30% or lower: yellow color
 - When battery level is 10% or lower: red color
 Charge the camera as soon as possible when the icon and indicator turn red. When the battery power runs out, a "RES" mark (red) appears. Charge the camera immediately.
- The remaining recording time is displayed in red color when it falls below 3 minutes. Replace the SD card with a new one.
- Recording cannot be performed when the recordable time is not displayed and the following message appears. Check the SD card when this occurs.

	SD card is write-protected
! INVALID	Writing/Reading error or unable to restore SD card
! INCORRECT	The SD card inserted does not meet the speed class requirements
IREC INH	An SDHC card is inserted when [4 GB Spanning] is set to [Off (SDXC)]
	An attempt has been made to record video in 60p or 60i to an SD card recorded in 50p or 50i in [AVCHD], and vice versa.

Memo : _____

- If the remaining time and battery indicator display disappears, tap **D**.
- When an AC adapter is connected while "System" is set to "4K" or "High-Speed", the battery level indicator will not be displayed.
- If an AC adapter is connected while "System" is set to "HD" and the battery is not fully charged, is displayed instead of the battery level indicator.

Playback Mode

- 1 Tap **PLAY** to select the playback mode.



- 2 Tap "ACTION".



- 3 Select "Display Media Info.," followed by tapping "SET".

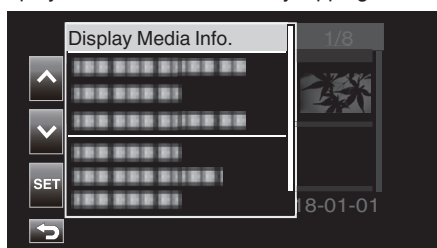

- 4 Check the remaining battery level and recording time.

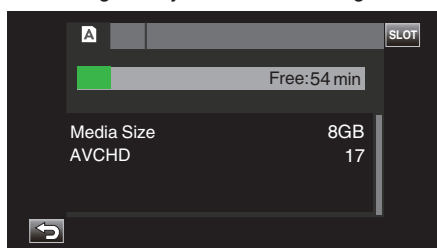

- The remaining recording time is displayed for the recording media that is currently selected. To switch the recording media that is displayed, tap **SLOT**.

Recording

Approximate Video Recording Time

Picture Quality		SDHC/SDXC Card							
		4 GB	8 GB	16 GB	32 GB	64 GB	128 GB	256 GB	512 GB
4K		6 m	13 m	26 m	53 m	1 h 45 m	3 h 30 m	7 h	14 h
HD	28M	16 m	33 m	1 h 7 m	2 h 15 m	4 h 30 m	9 h	18 h	36 h 10 m
	24M	19 m	39 m	1 h 18 m	2 h 37 m	5 h 15 m	10 h 30 m	21 h	42 h 10 m
	18M	25 m	51 m	1 h 44 m	3 h 30 m	7 h	14 h	28 h	56 h 10 m

- The recording time indicated above will change depending on the recording conditions.
- “28M” is configurable only when “Frame Rate” is set to “50p”/“60p”, while “24M”/“18M” is configurable only when “Frame Rate” is set to “50”/“60”.
- The still image has the same resolution as the video image.

Approximate Number of Still Images (Unit: Number of Shots)

Image Size	SDHC/SDXC Card				
	4 GB	8 GB	16 GB	32 GB	64 GB
3840x2160 (8.3M) (16:9)	800	1600	3100	4000	4000
1920x1080 (2M) (16:9)	3100	4000	4000	4000	4000

- The still image has the same resolution as the video image.

Approximate Duration of Built-in Battery

Record Format	Actual Recording Time	Continuous Recording Time (Maximum Recording Time)
4K (25p / 70M)	2 h 30m	4 h 30 m
HD (50i / 18M)	3 h	5 h 20 m
HD (50p / 28M)	2 h 30 m	4 h 40 m

- The above are values when “LCD Backlight” is set to “0”.
- The actual recording time is the recording time when operations such as starting/stopping recording, turning on/off the unit or zooming is performed repeatedly.
- Recording time may differ depending on the shooting environment and usage.
- When the recording time becomes extremely short even when the battery is fully charged, the battery needs to be replaced. For details on replacing the built-in battery (subject to a fee), consult the nearest JVC service center.

Playing Back Videos

You can select and play back the recorded videos from an index screen (thumbnail display).

Caution :

- Make a backup of important recorded data.
It is recommended that important recorded data be copied to a PC or other types of recording media (e.g., another SD card) for storage.
- This unit is a microcomputer-controlled device. Electrostatic discharge, external noise and interference (from a TV, a radio, etc.) might prevent it from functioning properly. In such a case, close the monitor screen to turn off the power and remove the AC adapter, then press the Reset button to reset this unit.

“Resetting this Unit” (p. 131)

- When there are many files in the media, it may take time for them to be displayed on the playback screen. Wait for a while as the POWER/ACCESS lamp blinks, indicating normal operation.
- Disclaimer
 - We shall not be held responsible for loss of recorded contents when recording videos/audio or playback cannot be operated due to malfunctions in this unit, provided parts, or SD card.
 - Once deleted, recorded contents (data), including data loss due to malfunctions in this unit, cannot be restored. Please be forewarned.
 - JVC will not be responsible for any lost data.
 - In order for quality improvement, defective recording medium is subject to be analyzed. Therefore, it may not be returned.

Normal Playback

Plays back the recorded videos.

- 1 Tap **PLAY** to select the playback mode.



- 2 Select a scene and tap **▶** to start playback.

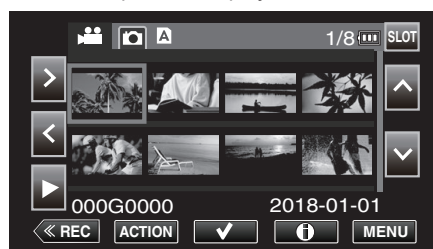

- Playback can also be started by tapping the thumbnail.
- Tapping the “SLOT” button switches the media to play back and changes the index screen (thumbnail display).
- The thumbnail images that are displayed on the index screen vary according to the recording format setting immediately before switching to the Playback mode as well as the recording format of the recorded video.
If the video to play back cannot be found, switch to the Recording mode and specify the recording format of the video to play back in “System”→“Record Set”→“Record Format”→“System” or “Frame Rate” of the menu.

		Recording Format upon Switching to Playback Mode				
		4K	HD		High-Speed	
			50p/60p	50i/60i		
Recorded Videos	4K	○	×	×	△	
	HD	50p/60p	×	○	△	×
		50i/60i	×	△	○	×
	High-Speed	△	×	×	○	

○: Thumbnail images are displayed and videos can be played back.
△: Substitute thumbnail images are displayed and videos cannot be played back. “Thumbnail Screen” (p. 129)
×: Thumbnail images are not displayed on the index screen.

- 3 Playback starts.
 - Tap **||** to pause.
 - Tap **◻** to return to the index screen.

Memo :

- Videos recorded in the 4K setting cannot be played back when “System” is set to “HD” or “High-Speed”.
- Videos recorded in the HD setting cannot be played back when “System” is set to “4K” or High-Speed.
- Videos recorded in the High-Speed setting cannot be played back when “System” is set to “4K” or HD.

Caution :

- While this unit may be used with the LCD monitor reversed and closed, the temperature rises more easily. Do not use this unit with the LCD monitor reversed and closed for long periods of time, or in places exposed to direct sunlight or high temperatures.
- The power may turn off to protect the circuit if the temperature of this unit rises too much.

Operation Buttons for Video Playback

During Index Screen Display



	Display	Description
①	Still Image Playback Mode Selection	Switches to the still image playback mode.
②	Video Playback Mode Selection	Switches to the video playback mode.
③	< >	Moves the cursor to the left or right.
④	▶	Starts playback.
⑤	◀◀REC	Switches to the recording mode.
⑥	ACTION	Opens the ACTION menu for configuring deletion and protection or for trimming.
⑦	✓	Videos to be deleted or protected can be selected in advance.
⑧	i	Displays the recording information of the recorded videos.
⑨	MENU	Displays the menu screen.
⑩	^ v	Moves the cursor upward or downward.
⑪	SLOT	Switches the SD card slot between Slot A and Slot B.

During Video Playback

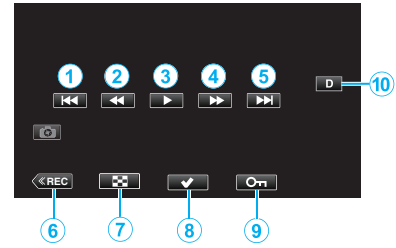

- When this unit is not operated, the operation buttons on the touch screen disappear automatically. Tap on the screen to display the operation buttons again.

	Display	Description
①	◀◀	Returns to the beginning of the scene Returns to the previous scene if tapped at the beginning of a scene.
②	◀◀ (during playback)	Reverse search (speed increases with each tap)
	◀◀ (during pause mode)	Frame-by-frame reverse playback Pressing and holding down the key allows frame-by-frame reverse playback to operate continuously.
③	▶	Starts playback
		Pause
④	▶▶ (during playback)	Forward search (speed increases with each tap)
	▶▶ (during pause mode)	Frame-by-frame playback Pressing and holding down the key allows frame-by-frame playback to operate continuously.
⑤	▶▶▶	Advances to the next scene
⑥	◀◀REC	Switches to the recording mode.
⑦	⏏	Stop (returns to index screen)
⑧	✓	Videos to be deleted or protected can be selected in advance.
⑨	⏏	Protects a video to prevent it from being erased accidentally.
⑩	D	Switches the display between full (D?) and simple (D) with every tap of the button. <ul style="list-style-type: none"> Simple display: Some displays disappear automatically when the screen is not operated. Full display: Displays everything. The display button changes from D to D?. When the power is turned off, the display setting will revert to simple display (D).

“ACTION” Menu (Video)



	Display	Description
①	Display Media Info.	Displays the recording information of the recorded scenes. “Media Information Screen (Videos Only)” (p. 53)
②	Select All Scenes	Selects all the recorded scenes.
③	Select Range	Selects recorded scenes by specifying a range. “Selecting Multiple Discontinuous Scenes for Enabling or Canceling Protection” (p. 63) “Selecting and Deleting Multiple Continuous Scenes” (p. 61)
④	Deselect All	Clears all the selections.
⑤	Protect	Protects the selected scenes. “Protecting Video Images” (p. 63)
⑥	Remove Protection	Cancel the preconfigured protection.
⑦	Delete Scenes	Deletes the selected scenes. “Deleting Unwanted Files” (p. 59)
⑧	Trim This Scene	Trims the selected scene. “Trimming Recorded Videos” (p. 66)

Media Information Screen (Videos Only)

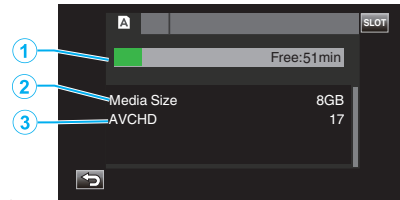

	Display	Description
①	Remaining Recording Time	Displays the remaining recording time.
②	Media Size	Displays the capacity of the media.
③	Recording Format	Displays the recording format and number of files.

Adjusting the Volume of Videos

You can use the zoom/volume lever to control the volume.

Turn up the volume

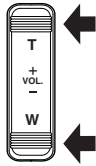

Turn down the volume

Checking the Recording Date and Other Information

The recording information of the recorded videos can be displayed for viewing.

1 Tap <<PLAY to select the playback mode.



2 Select the scene (file) for which information is to be displayed for viewing, followed by tapping **i**.



3 Check the recording information.

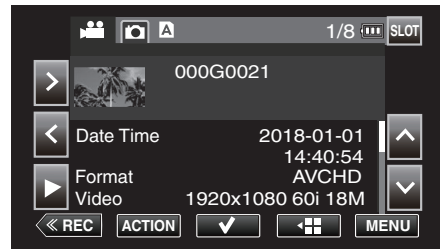

- Tap ^ or v as needed to scroll through the displayed information. (^ and v are not available for still images.)
- Tap ▶ to start playback.
Playback can also be started by tapping the thumbnail.
- <> can be used to display information of the previous or next video.
- Tap **⌘** to return to the thumbnail screen.

Playing Back Still Images

You can select and play back the recorded still images from an index screen (thumbnail display).

- 1 Tap **PLAY** to select the playback mode.



- 2 Tap the  (Still Image Playback Selection) button to switch to the Still Image mode.



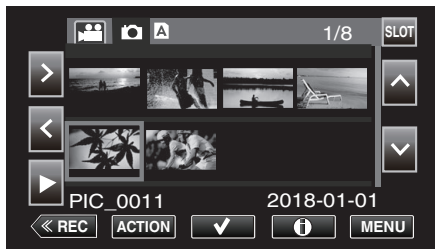

- 3 Select a file (still image) and tap .

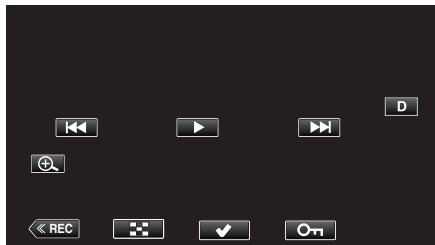

- Playback can also be started by tapping the thumbnail.

- 4 Start playback.



- Tap  to return to the index screen.

Operation Buttons for Still Image Playback

During Index Screen Display

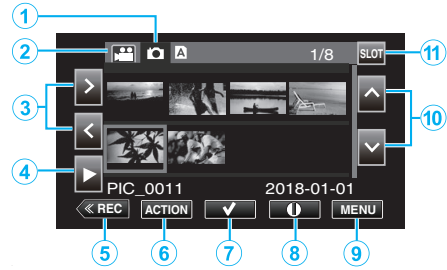

	Display	Description
①	Still Image Playback Mode Selection	Switches to the still image playback mode.
②	Video Playback Mode Selection	Switches to the video playback mode.
③	< >	Moves the cursor to the left or right.
④	▶	Starts playback.
⑤	◀◀ REC	Switches to the recording mode.
⑥	ACTION	Opens the ACTION menu for configuring deletion and protection or for trimming.
⑦	✓	Videos to be deleted or protected can be selected in advance.
⑧	i	Displays the recording information of the recorded videos.
⑨	MENU	Displays the menu screen.
⑩	^ v	Moves the cursor upward or downward.
⑪	SLOT	Switches the SD card slot between Slot A and Slot B.

During Still Image Playback

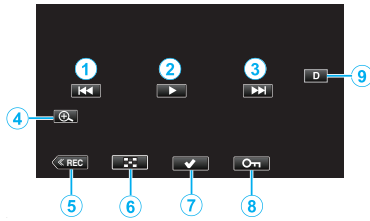

- When this unit is not operated, the operation buttons on the touch screen disappear automatically. Tap on the screen to display the operation buttons again.

	Display	Description
①	◀◀	Returns to the previous still image <ul style="list-style-type: none"> You can perform the same operation with the zoom lever.
②	▶ /	Starts/pauses slideshow
③	▶▶	Advances to the next still image <ul style="list-style-type: none"> You can perform the same operation with the zoom lever.
④	⊕	Enlarges the view.
⑤	◀ REC	Switches to the recording mode.
⑥	📊	Returns to index screen
⑦	✓	Videos to be deleted or protected can be selected in advance.
⑧	🔒	Protects a video to prevent it from being erased accidentally.
⑨	D / D?	Switches the display between full (D?) and simple (D) with every tap of the button. <ul style="list-style-type: none"> Simple display: Some displays disappear automatically when the screen is not operated. Full display: Displays everything. The display button changes from D to D?. When the power is turned off, the display setting will revert to simple display (D).

Memo :

- Tap the touch screen to operate.

Caution :

- This unit is a microcomputer-controlled device. Electrostatic discharge, external noise and interference (from a TV, a radio, etc.) might prevent it from functioning properly. In such a case, close the monitor screen to turn off the power and remove the AC adapter, then press the Reset button to reset this unit.

“Resetting this Unit” (☞ p. 131)

“ACTION” Menu (Still Image)

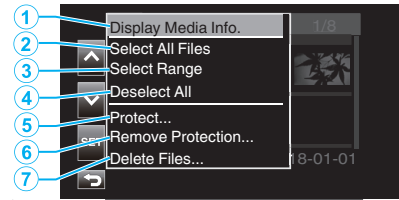

	Display	Description
①	Display Media Info.	Not available for selection.
②	Select All Files	Selects all the video recording files.
③	Select Range	Selects video recording files by specifying a range.
④	Deselect All	Clears all the selections.
⑤	Protect	Protects the selected files.
⑥	Remove Protection	Cancels the preconfigured protection.
⑦	Delete Files	Deletes the selected files.

Slideshow Playback

Still images can be played back in a slideshow.
Tap ▶ during still image playback to start the slideshow.

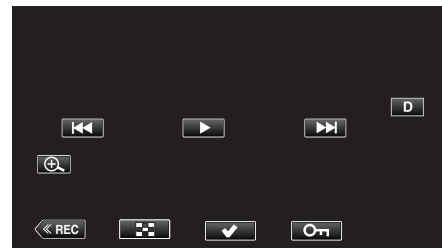

“Operation Buttons for Still Image Playback” (☞ p. 55)

Connecting to and Viewing on TV

You can connect this unit to a TV for playback. The image quality on the TV varies with the type of TV in use.

- Refer also to the instruction manual of the TV in use.
- To display the date and time on TV, set both “Date/Time” and “Display On TV” to “On”.

“Date/Time” (☞ p. 111)

“Display On TV” (☞ p. 112)

Unnatural Displays on TV

Trouble	Action
HDMI-CEC functions do not work properly, and the TV does not work in conjunction with this unit.	<ul style="list-style-type: none"> • TVs may operate differently depending on the specifications, even if they are HDMI-CEC compliant. Therefore, the HDMI-CEC functions of this unit cannot be guaranteed to operate in combination with all the TVs. In such cases, set “HDMI Control” to “Off”. <p>“HDMI Control” (☞ p. 112)</p>
The language on the display changed.	<ul style="list-style-type: none"> • It may occur when you connect this unit to a TV with different language setting using an HDMI mini cable.

Caution :

- Turn off this unit and the TV before making any connection.
- Before inserting or removing the SD card, close the LCD monitor and ensure that the POWER/ACCESS lamp goes off.

Connecting via the HDMI Mini Connector

By connecting to the HDMI mini terminal of this unit, 4K video recordings can be played back in 4K quality on TV sets that support 4K resolution and in HD quality in the case of high-definition TVs.

- Use a High Speed HDMI mini cable as the HDMI mini cable when not using the provided one.
- Videos on the camera cannot be played back on TVs that do not have a HDMI input terminal.
- Refer also to the instruction manual of the TV in use.

1 Connect to a TV.

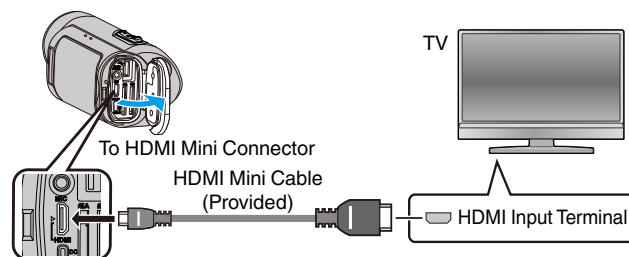

2 Connect the AC adapter to this unit.

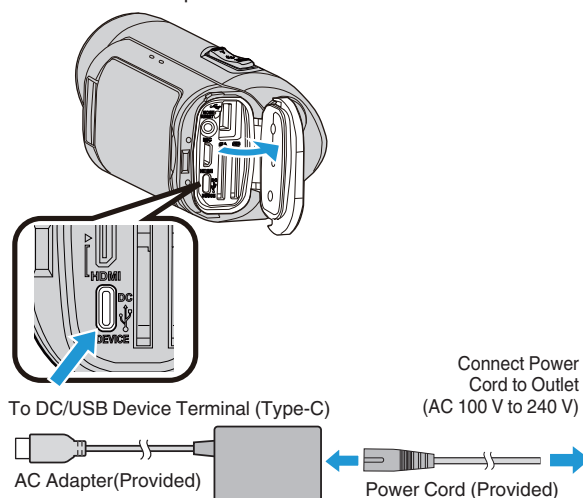

3 Open the LCD monitor.

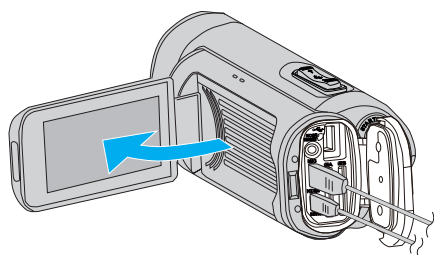

- The unit turns on automatically.

- 4 Tap **PLAY** to select the playback mode.



- 5 Press the input selection button on the TV to switch to the input to the terminal that is connected to this camera.



- 6 Select a scene (file) and tap **▶** to start playback.



- Playback can also be started by tapping the thumbnail.
 “Playing Back Videos” (p. 51)
 “Playing Back Still Images” (p. 55)

Memo :

- Change the settings in “HDMI Out” according to the connection.
 “HDMI Out” (p. 112)
- When connected to the TV via the HDMI mini cable, images and sounds may not be output properly depending on the TV connected. In such cases, perform the following operations.
 1) Disconnect the HDMI mini cable and connect it again.
 2) Turn off and on this unit again.
- For questions about the TV or method of connection, contact your TV's manufacturer.

Operating in Conjunction with TV via HDMI

Connecting this unit to an HDMI-CEC enabled TV using the HDMI mini cable allows linked operations with the TV to be performed.

- HDMI-CEC (Consumer Electronics Control) is an industry standard that enables interoperability between HDMI-CEC compliant devices that are connected via HDMI cables.

Memo :

- Not all HDMI control devices comply with the HDMI-CEC standard. The HDMI control function of this unit will not work when connected to these devices.
- This unit is not guaranteed to operate with all HDMI-CEC enabled devices.
- Depending on the specifications of each HDMI-CEC enabled device, some functions may not work with this unit. (For details, refer to the instruction manual of your TV.)
- Unintended operations may occur with some connected devices. In these cases, set “HDMI Control” to “Off”.
 “HDMI Control” (p. 112)

Preparations

- Connect an HDMI mini cable between this unit and the TV.
 “Connecting via the HDMI Mini Connector” (p. 57)
- Turn on the power of the TV and configure the HDMI CEC setting to “On” (refer also to the instruction manual of the TV in use).
- Set “HDMI Control” in the A/V Set menu to “On”.
 “HDMI Control” (p. 112)

Operation Method 1

- 1 Turn on this unit.
- 2 Select the playback mode.
 - TV turns on automatically and switches to HDMI input mode when this unit is turned on.

Operation Method 2

- 1 Turn off the TV.
 - This unit turns off automatically.

Memo :

- Depending on the TV connected, the display language of this unit will automatically switch to the language that is selected for the TV when this unit is turned on.
 (Applicable only when the display language selected on the TV is supported by this camera) To use a display language different from that used on the TV, set “HDMI Control” to “Off”.
- The display language of the TV will not switch automatically, even if the display language of this unit is changed.
- These functions may not work correctly when devices such as amplifier and selector are connected. In such cases, set “HDMI Control” to “Off”.
- If HDMI-CEC does not work properly, turn off and on this unit again.

Deleting Unwanted Files

Delete unwanted videos and still images when the space in the recording media is running out.

Doing so frees up more space in the recording media.

“Deleting One Scene” (p. 59)

“Selecting and Deleting Multiple Scenes” (p. 60)

“Deleting All Scenes” (p. 62)

Memo :

- Deleted files cannot be restored.
- Files that are protected cannot be deleted.
Release protection before deleting the file.
- “Protecting Video Images” (p. 63)
- Be sure to back up important video files on a PC or any other media.
- “Backing up Data on a Computer” (p. 68)

Deleting One Scene

Delete the scene that is currently being displayed (played).

Caution :

- Deleted files cannot be restored.

- 1 Tap **PLAY** to select the playback mode.

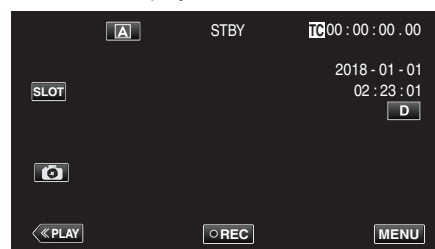

- 2 Select the scene to delete and tap “ACTION”.

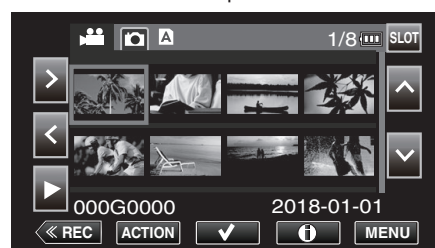

- While the video mode is shown in the image, the same operations apply for the still image mode.

- 3 Select “Delete Scenes” and tap “SET”.

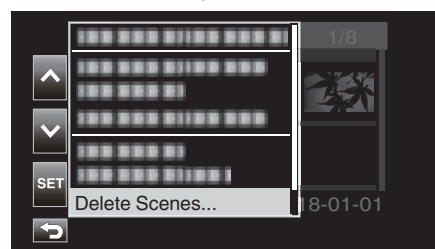

- For still images, select “Delete Files...”.

- 4 Select “This Scene” and tap “SET”.

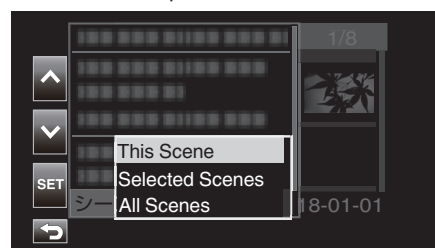

- For still images, select “This File”.

- 5 Select “Delete” and tap “SET”.

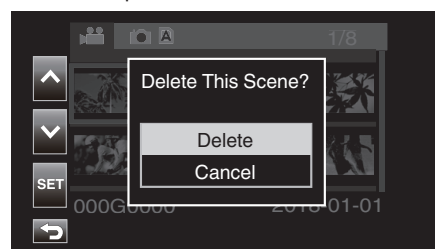

- To cancel the deletion, select “Cancel” and tap “SET”.

Selecting and Deleting Multiple Scenes

Deletes the selected files.

Caution :

- Deleted files cannot be restored.

Selecting and Deleting Multiple Discontinuous Scenes

1 Tap «PLAY to select the playback mode.



2 Align the cursor with the scene (video) to delete and tap ✓. Repeat the same step.



3 Tap "ACTION".



- While the video mode is shown in the image, the same operations apply for the still image mode.

4 Select "Delete Scenes" and tap "SET".



5 Select "Selected Scenes" and tap "SET".

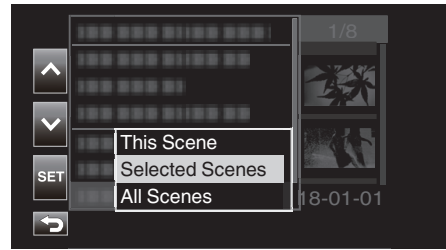

- For still images, select "Selected Files".

6 Select "Delete" and tap "SET".

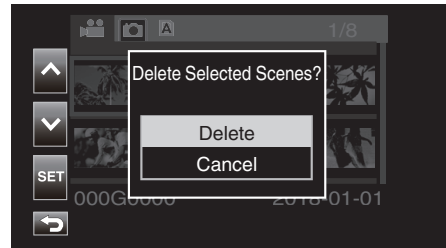

- To cancel the deletion, select "Cancel" and tap "SET".

Selecting and Deleting Multiple Continuous Scenes

1 Tap «PLAY to select the playback mode.



2 Tap "ACTION".



- While the video mode is shown in the image, the same operations apply for the still image mode.

3 Select "Select Range" and tap "SET".

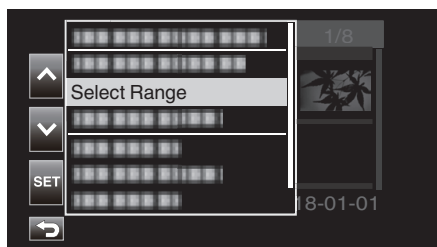

4 Select the starting point and tap "SET".

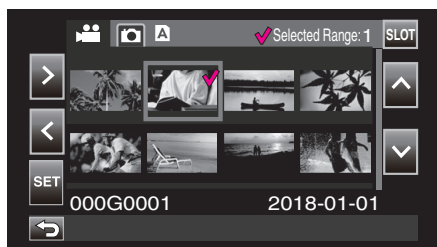

5 Select the ending point and tap "SET".

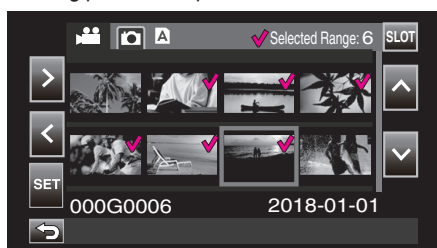

- The color of the ✓ changes from pink to green.

6 Tap "ACTION".

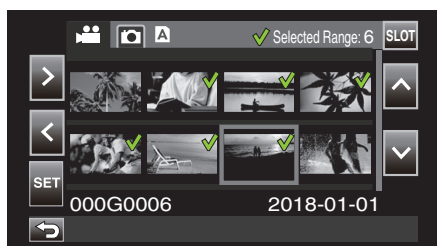

7 Select "Delete Scenes" and tap "SET".

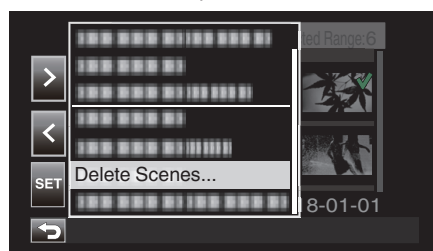

8 Select "Selected Scenes" and tap "SET".

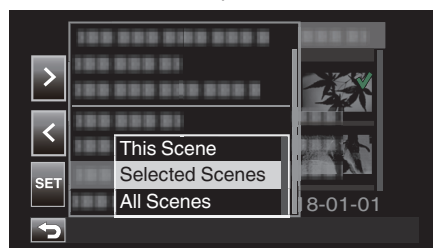

9 Select "Delete" and tap "SET".

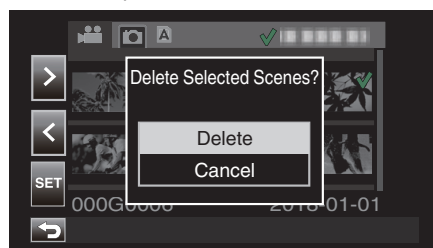

- To cancel the deletion, select "Cancel" and tap "SET".

Deleting All Scenes

- 1 Tap «PLAY to select the playback mode.



- 2 Tap "ACTION".



- 3 Select "Delete Scenes" and tap "SET".



- 4 Select "All Scenes" and tap "SET".

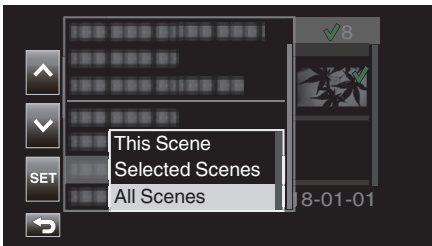

- 5 Select "Delete" and tap "SET".

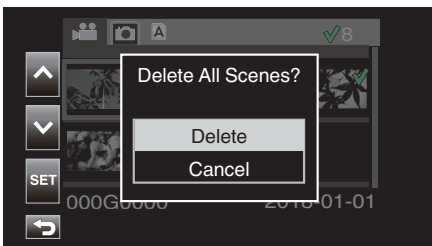

- To cancel the deletion, select "Cancel" and tap "SET".

Protecting Video Images

Protect important videos/still images to prevent them from being deleted accidentally.

“Protecting/Canceling Protection of the Displayed (Playback) Scene” (p. 63)

“Protecting/Releasing Protection of Selected Files” (p. 63)

“Protecting/Canceling Protection of All Scenes” (p. 65)

Caution :

- When the recording media is formatted, even the protected files will be deleted.

Protecting/Canceling Protection of the Displayed (Playback) Scene

Protect or cancel the protection of the file that is currently being displayed (played).

■ Protecting a File

On the playback or paused screen, tap **On**.

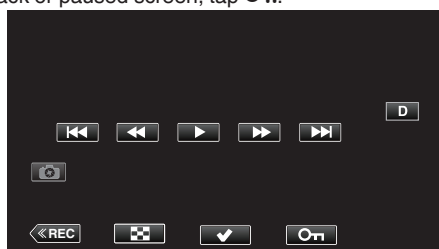

■ Canceling Protection

On the playback or paused screen of the protected scene, tap **On**.

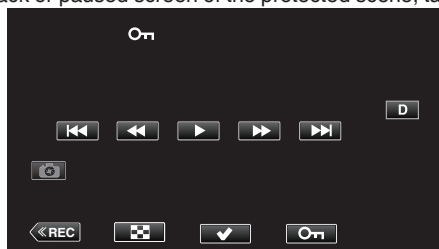

Caution :

- Protect or cancel protect operation cannot be performed during fast forward or fast reverse of the video.

Protecting/Releasing Protection of Selected Files

Protects or releases protection of the selected files.

Selecting Multiple Discontinuous Scenes for Enabling or Canceling Protection

1 Tap **PLAY** to select the playback mode.



2 Select the scene to protect and tap ✓.



- Repeat the same step to select other scenes to protect.
- To cancel protection of a scene, select the corresponding scene and tap ✓.
- While the video mode is shown in the image, the same operations apply for the still image mode.

3 Tap ACTION.

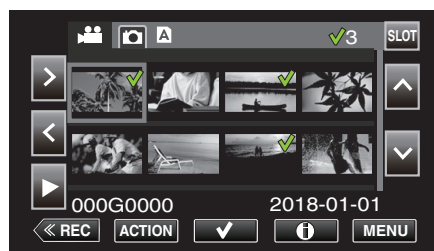

4 Select “Protect” and tap “SET”.



- To cancel protection, select “Remove Protection” and tap “SET”.

5 Select “Selected Scenes” and tap “SET”.

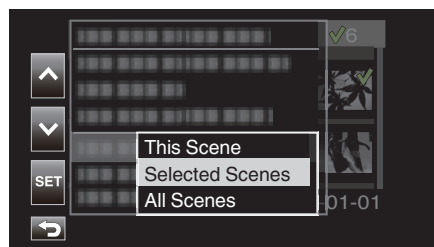

- For still images, select “Selected Files”.

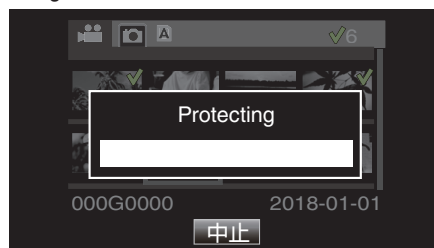

- To cancel protection, tap “Stop”.
- A **On** icon is displayed for the selected scene.
- When protection of a scene is canceled, the **On** icon that is appended to the selected scene will disappear.

Selecting Multiple Continuous Scenes for Enabling or Canceling Protection

1 Tap «PLAY to select the playback mode.



2 Tap "ACTION".



- While the video mode is shown in the image, the same operations apply for the still image mode.

3 Select "Select Range" and tap "SET".

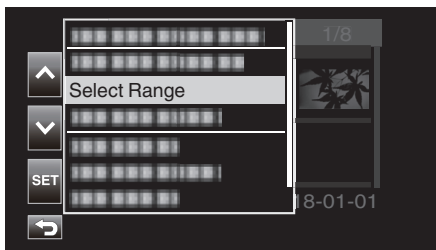

4 Select the starting point and tap "SET".

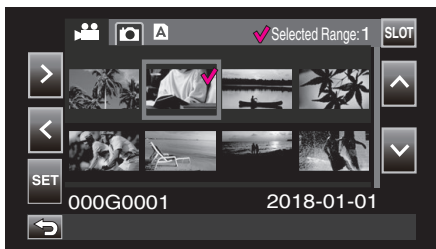

5 Select the ending point and tap "SET".

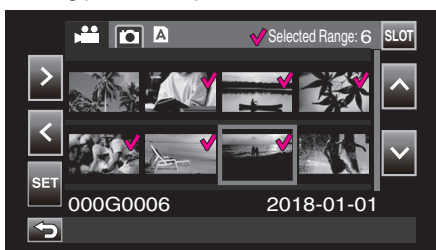

- The color of the ✓ changes from pink to green.

6 Tap "ACTION".

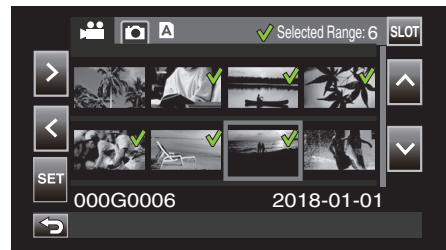

7 Select "Protect" and tap "SET".

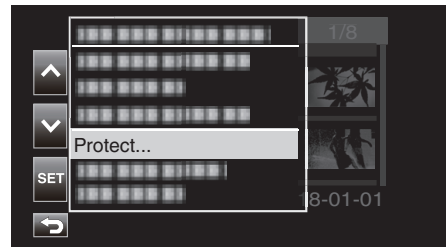

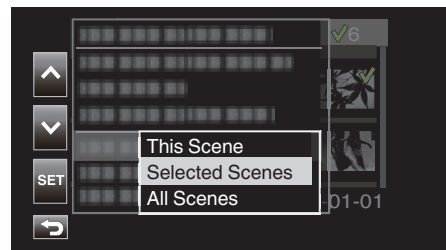

- To cancel protection, select "Remove Protection" and tap "SET".

8 Select "Selected Scenes" and tap "SET".

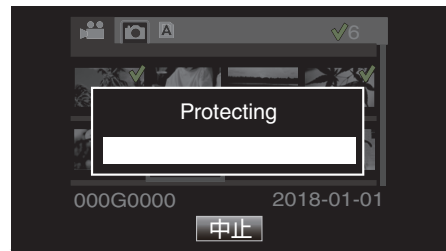

- For still images, select "Selected Files".



- To cancel protection, tap "Stop".
- A  icon is displayed for the selected scene.
- When protection of a scene is canceled, the  icon that is appended to the selected scene will disappear.

Protecting/Canceling Protection of All Scenes

1 Tap «PLAY to select the playback mode.



2 Tap "ACTION".



3 Select "Protect" and tap "SET".

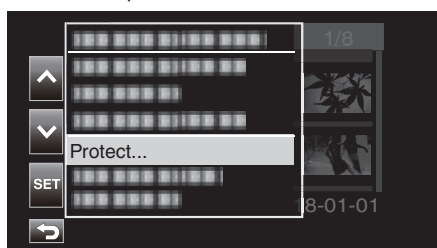

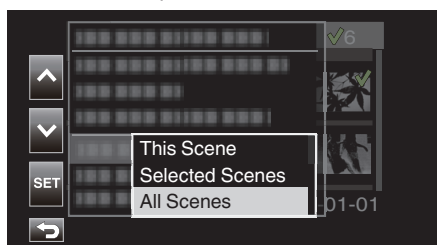

- To cancel protection, select "Remove Protection" and tap "SET".

4 Select "All Scenes" and tap "SET".

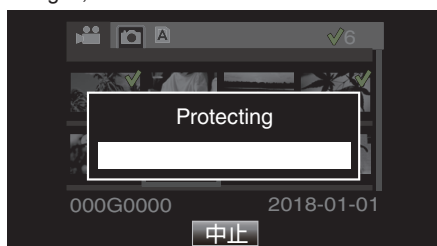

- For still images, select "All Files".



- To cancel protection, tap "Stop".
- A  icon is displayed for all the scenes.
- When protection is canceled, the  icon that is appended to all the scenes will disappear.

Trimming Recorded Videos

It is possible to crop (trim) the necessary parts of a scene that is recorded in an SD card. The trimmed scene is saved as a new file on the same SD card as the original clip. The original scene will remain intact.

1 Tap **PLAY** to select the playback mode.



2 Select the scene to trim and tap "ACTION".



3 Select "Trim This Scene" and tap "SET".

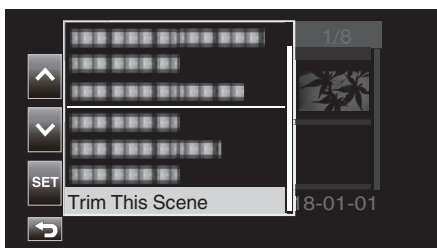

4 Tap **||** at the point to start cropping.

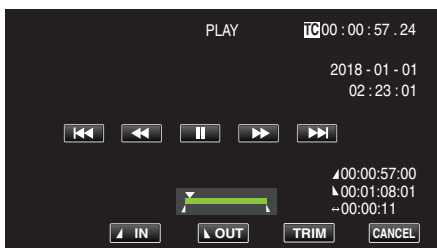

5 Tap "IN".

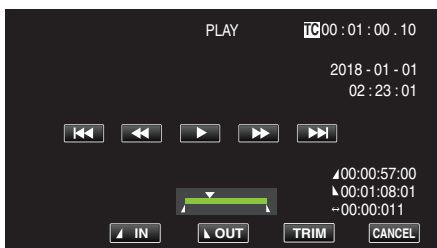

The point to start cropping is confirmed.

6 Tap **▶** to start playback.



7 Tap **||** at the point to end cropping.

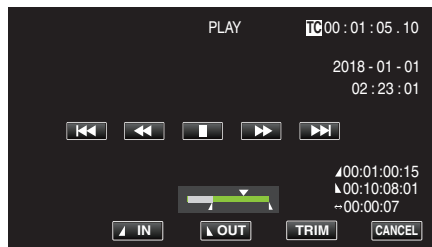

8 Tap "OUT".

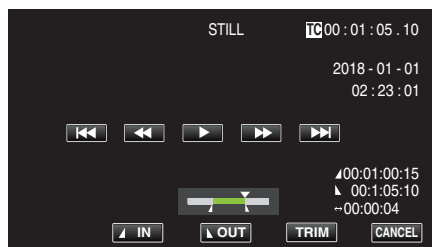

The point to end cropping is confirmed.

9 Tap "TRIM".

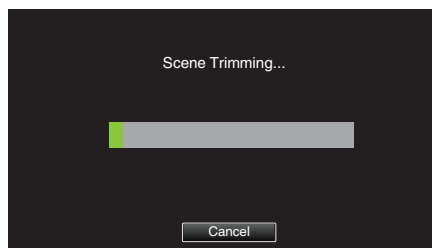

Trimming is complete when "Successfully Completed." appears.

Memo :

- The trimmed scene will be saved to the same card slot as that of the original scene.
- The display appears in yellow if the recording duration corresponds to any of the following. Trimming cannot be performed in this case.
"4K": 3 minutes or longer; setting other than "4K": 10 minutes or longer.
- The display appears in yellow if the recording duration is longer than the recordable time on the storage media. Trimming cannot be performed in this case.
- To return to the thumbnail screen while trimming is in progress, tap CANCEL.
- The IN and OUT points may deviate by up to 1 second prior to the specified IN point and 1 second after the specified OUT point respectively.

Capturing a Still Image from One Scene in a Video

You can capture still images of the scenes you like in the recorded videos.

- 1 Tap **PLAY** to select the playback mode.



- 2 Select a scene and tap **▶** to start playback.



- 3 Tap pause **||** at the desired scene during playback.

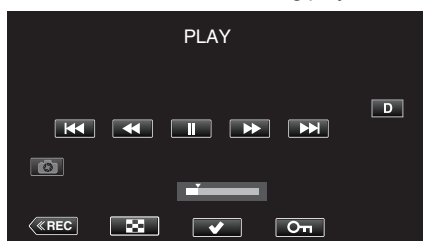

- After pausing the video, you can fine-tune the point to capture by tapping forward slow-motion **▶▶** and reverse slow-motion **◀◀**.

- 4 Tap **📷**.



Memo :

- The cropped still image has the same resolution as the video image.
- Cropped still images are saved to the selected SD card.

Backing up Data on a Computer

The following describes the way to back up videos and still images in the SD card to a PC.

By copying the entire folder from the SD card, it is possible to write the files back to the SD card for playback on the camera.

Memo :

- Backup can be performed without installing PowerDirector.
- Playback on the camera will fail if the backup files on the PC are moved or when their names are changed.
- Video files output using PowerDirector and files recorded by a different camera cannot be played back on this camera.

When Using Windows 10 or Windows 8.1

Backing up Data from an SD Card to a PC

1 Insert an SD card.

Insert the SD card that contains the recorded file into the SD card slot of the PC or an SD card reader that is connected to the PC. If an Auto Play dialog box or app appears, close it.

Memo :

- If there is no SD card slot on the PC or you do not have a card reader, insert the SD card into the camera and connect the camera to a PC using a USB cable. Then proceed to step.

Caution :

- When connecting the camera to a PC to perform backup, the operation cannot be completed if the remaining battery power is not enough. Charge the battery fully first.

2 Open the “Start menu”, and click “This PC” under “Windows System”.

- For Windows 8.1, click  to open “Apps”.

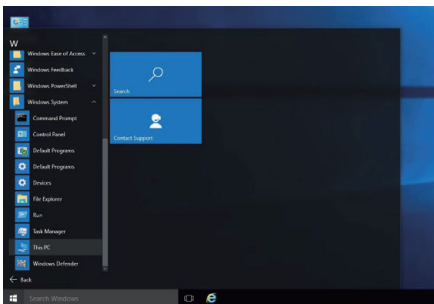

- If a “This PC” icon is shown on desktop, double-click the icon to open “This PC”.

3 Right-click the SD card drive and select “Copy”.

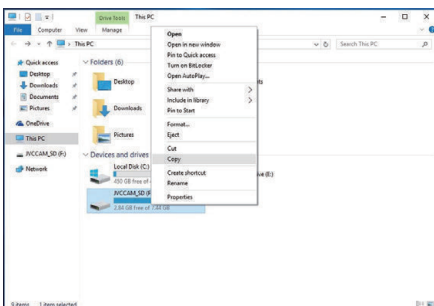

4 Right-click “Picture” and select “Paste”.

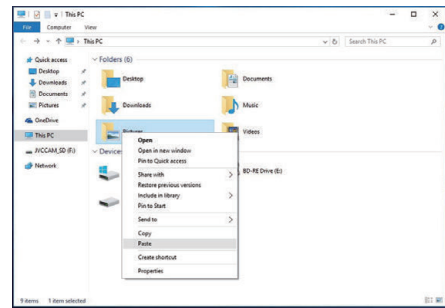

- File copy starts.
- Files can also be saved to a folder other than “Picture”.

5 Assign an easy-to-understand name for the copied folder, such as the date.

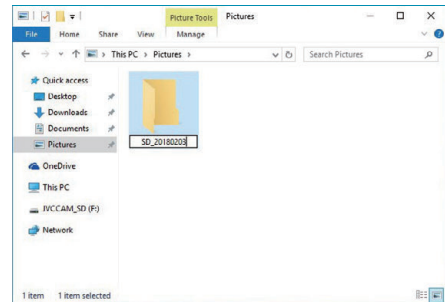

6 Select and right-click the SD card drive, followed by selecting “Remove”.

Writing Files Back from the PC to the SD Card

- 1 Insert an SD card.
 - Use an SD card that is formatted using the camera.
 - Insert an SD card into the SD card slot or SD card reader of the PC.
 - If an Auto Play dialog box or app appears, close it.
- 2 Open the “Start menu”, and click “This PC” under “Windows System”.
 - For Windows 8.1, click  to open “Apps”.

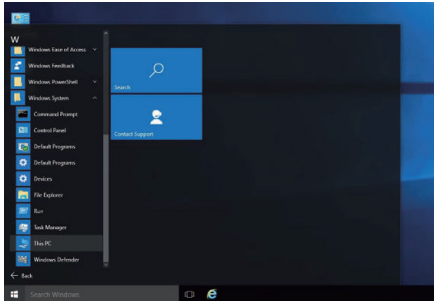

- If a “This PC” icon is shown on desktop, double-click the icon to open “This PC”.
- 3 Click the SD card drive and check the folder.
 - Delete accordingly if there are folders in “DCIM”“PRIVATE” “EXTMOV”.
 - If files that are needed still remain in the SD card, perform the step in “Backing up Data from an SD Card to a PC” (p. 68) first.
 - 4 Open the folder that contains contents of the SD card.

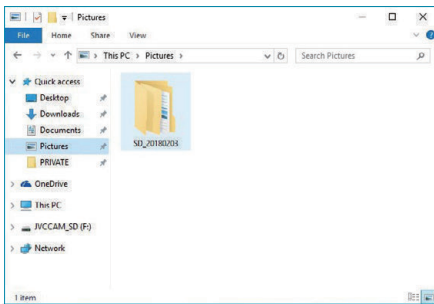

- 5 Select and right-click the folder, followed by selecting “Copy”.
Select the “DCIM” and “PRIVATE” folders.

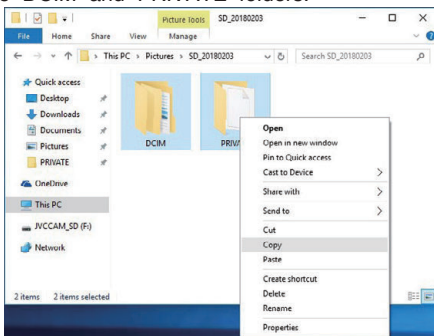

- 6 Select and right-click the SD card drive, followed by selecting “Paste”.

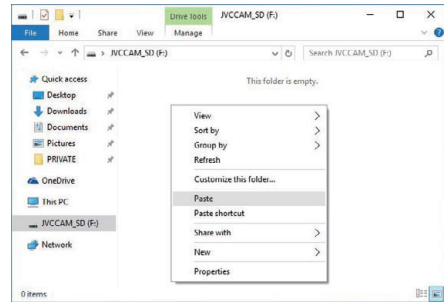

File copy starts.

- 7 Select and right-click the SD card drive, followed by selecting “Remove”.

Copying

When Using Windows 7

Backing up Data from an SD Card to a PC

1 Insert an SD card.

Insert the SD card that contains the recorded file into the SD card slot of the PC or an SD card reader that is connected to the PC. If an Auto Play dialog box or app appears, close it.

Memo :

- If there is no SD card slot on the PC or you do not have a card reader, insert the SD card into the camera and connect the camera to a PC using a USB cable. Then proceed to step.

Caution :

- When connecting the camera to a PC to perform backup, the operation cannot be completed if the remaining battery power is not enough. Charge the battery fully first.

2 Click “Computer” in the Start menu.

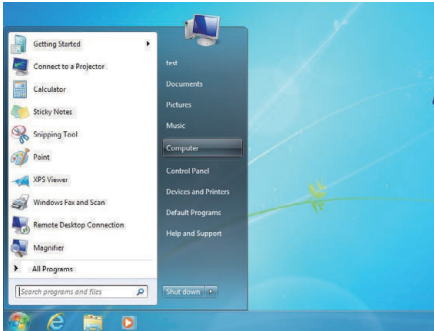

- If a “Computer” icon is shown on desktop, double-click the icon to open “Computer”.

3 Right-click the SD card drive and select “Copy”.

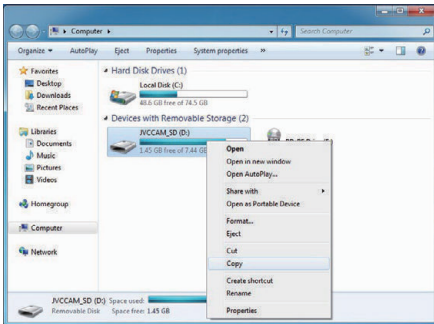

4 Right-click “Picture” and select “Paste”.

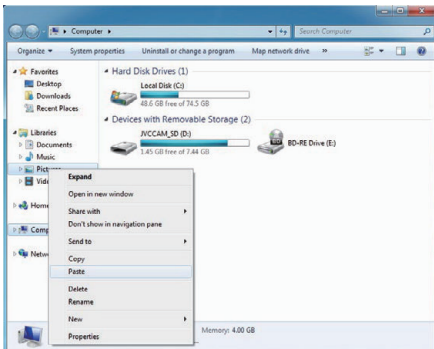

- File copy starts.
- Files can also be saved to a folder other than “Picture”.

5 Assign an easy-to-understand name for the copied folder, such as the date.

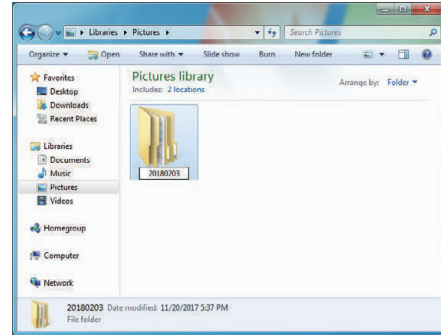

6 Select and right-click the SD card drive, followed by selecting “Remove”.

Writing Files Back from the PC to the SD Card

- 1 Insert an SD card.
 - Use an SD card that is formatted using the camera.
 - Insert an SD card into the SD card slot or SD card reader of the PC.
 - If an Auto Play dialog box or app appears, close it.
- 2 Click “Computer” in the Start menu.

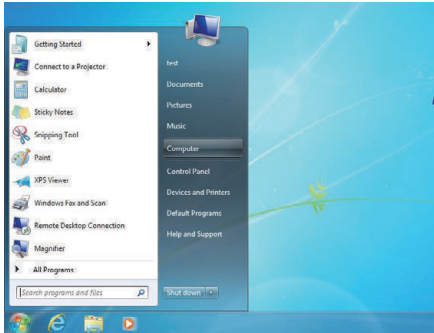

- If a “Computer” icon is shown on desktop, double-click the icon to open “Computer”.

- 3 Click the SD card drive and check the folder.
 - Delete accordingly if there are folders in “DCIM”“PRIVATE” “EXTMOV”.
 - If files that are needed still remain in the SD card, perform the step in “Backing up Data from an SD Card to a PC” (p. 70) first.
- 4 Open the folder that contains contents of the SD card.

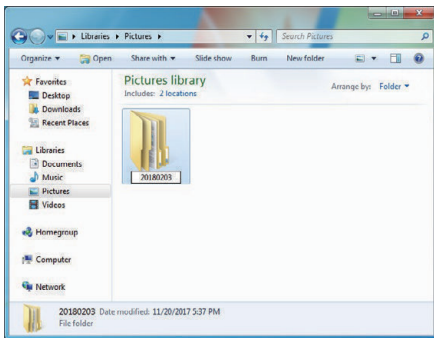

- 5 Select and right-click the folder, followed by selecting “Copy”.
- Select the “DCIM” and “PRIVATE” folders.

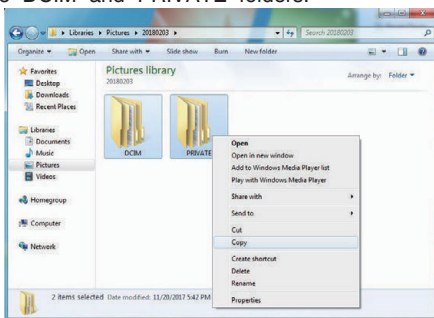

- 6 Select and right-click the SD card drive, followed by selecting “Paste”.

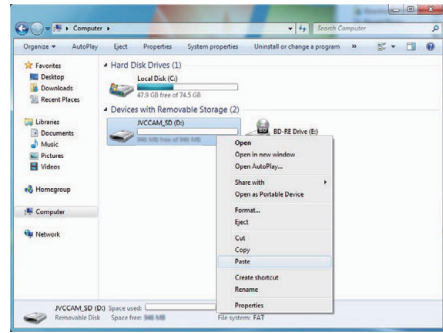

File copy starts.

- 7 Select and right-click the SD card drive, followed by selecting “Remove”.

Using CyberLink PowerDirector

The CyberLink PowerDirector 14 video-editing software can be downloaded for use.

Power Director offers a diverse variety of editing functions such as cutting, trimming, merging, transition, effect and text addition.

After editing, the files can be converted to a different format according to the intended use, uploaded to movie websites or made into movie discs.

- For more details on how to operate PowerDirector, please refer to the PowerDirector User's Guide. The User's Guide can be downloaded from the Download page.

If you encounter any problems with the provided software CyberLink PowerDirector, please consult the "CyberLink Customer Support".

■ Homepage

(Deutschland)

<https://de.cyberlink.com/support/index.html>

(France)

<https://fr.cyberlink.com/support/index.html>

(España)

<https://es.cyberlink.com/support/index.html>

(Italia)

<https://it.cyberlink.com/support/index.html>

(United Kingdom)(Rest of Europe)

<https://www.cyberlink.com/support/index.html>

Installing PowerDirector

1 Check the performance of the PC.

- Check to ensure that the performance of the PC in use meets the following system requirements.
- If you are unsure of the specifications of the PC in use, refer to "Verifying System Requirements (Guideline)" (p. 74).

OS	Windows® 10 (32 bits/64 bits) Windows® 8.1 (32 bits/64 bits) Windows® 7 (32 bits/64 bits) (64 bits recommended)
CPU	Intel® Core i5 or higher (recommended) (For editing of 4K videos, Intel® Core i7 or higher is recommended)
RAM	3 GB or higher recommended (32 bits) 6 GB or higher recommended (64 bits)
Display	A 4K-compatible display is required for playing back in 4K resolution
Graphics	VRAM 1 GB or higher recommended A 4K-compatible video card is required for playing back in 4K resolution

- Other requirements

To create a disc, a rewritable disc drive that supports the intended disc type is needed.

Memo :

- For more information on the system requirements, please refer to the Help menu of PowerDirector.

2 Check the serial number.

- Input of the serial number is needed during download.
- The serial number is printed on the label on the bottom surface of the camera.

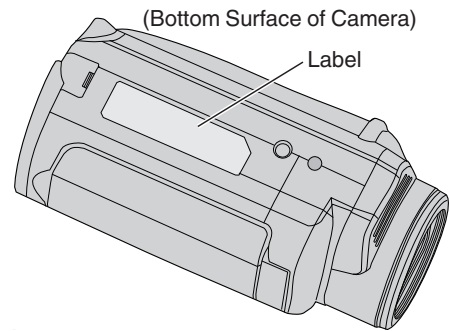

3 Download.

- Open the Download page from the link below.
<http://www.cyberlink.com/JVC/PDR/>
- Follow the instructions on the Download page to download the file.
- Write down the product key that is displayed on the Download page or leave it displayed until you are ready to install.

4 Install.

- Double-click the downloaded file to start installation.
- Follow the instructions displayed on the installer to complete the installation.

Using PowerDirector

1 Start up.

- Double-click the “CyberLink PowerDirector” icon on the Desktop screen.



- Input of the product key is needed at the initial startup. (Product key displayed on the Download page)
- After the launcher has started up, select “Full Function Editor” under normal circumstances.

2 Load a file.

- Display the media room on the editing screen (in the startup state), followed by selecting “Load Media”→“Load Media Files” to load a video or still image file.
- The loaded file is displayed as a media room thumbnail.
- Although it is also possible to load a file from the SD card, it has to be in the same drive when you save a project and proceed to editing.

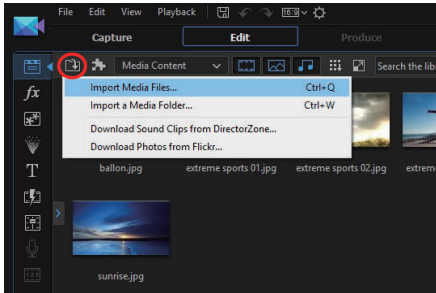

3 Edit.

- Drag and drop the media room thumbnail in the video track of the timeline.
- Editing operations such as trimming, merging and application of effects are possible on the timeline.
- The edited data can be saved with “File”→“Save Project”.

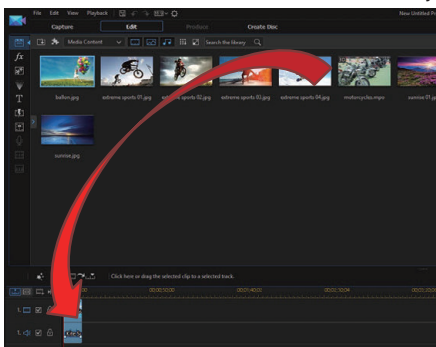

Memo :

- To play back (view) a video file, select the media room thumbnail without adding the file to the timeline, followed by clicking “Playback” on the preview window. The videos can be played back in high image quality.

4 Output.

- After editing is complete, files can be output as different video files or uploaded to movie websites with “Output”. “Create Disk” can be used to create different types of discs.

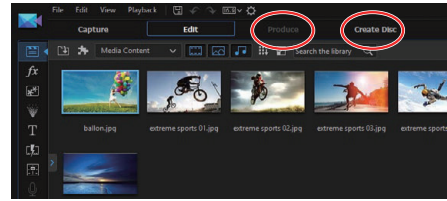

Memo :

- Output of 4K video files may take a long time (10 times longer than the actual time) even under the recommended environment.
- Video files output with PowerDirector cannot be played back on a camera.
- A device or player software program that is compatible with the corresponding disc format is needed to play back a disc created with PowerDirector.

Verifying System Requirements (Guideline)

Windows 10

- 1 Right-click the Start button, followed by selecting and clicking “System”.

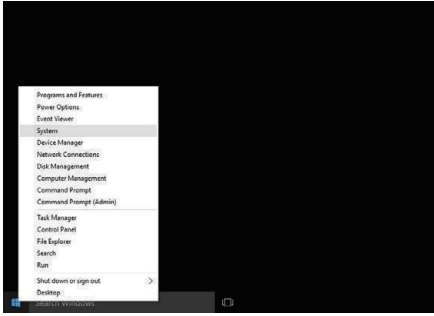

- 2 Check the system information.

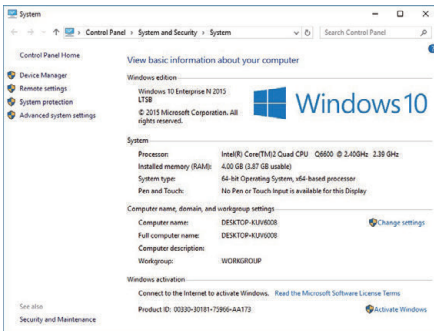

- If a “This PC” icon is shown on desktop, right-click the icon and select “Properties” in the menu to display your computer information.

Windows 8.1

- 1 Display “Apps”.
Click .

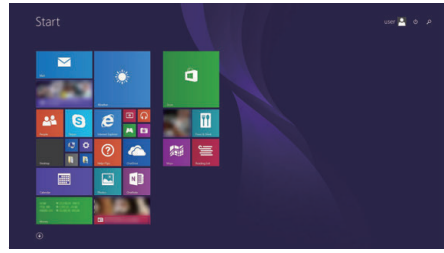

- 2 Right-click “PC” in the “Windows System Tool” menu to select the checkbox.

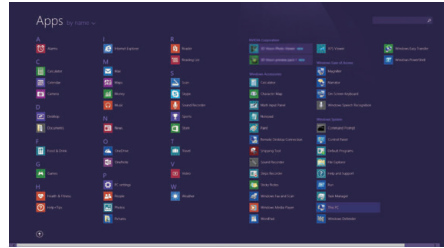

- 3 Click “Properties” on the bottom bar to display.

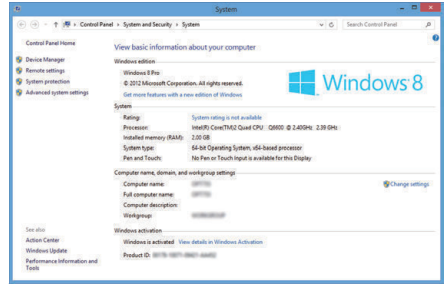

- If a “Computer” icon is shown on desktop, right-click the icon and select “Properties” in the menu to display your computer information.

Windows 7

1 Click the start button.

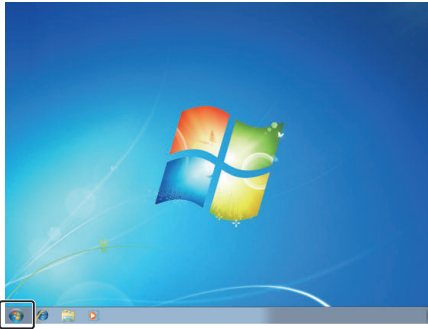

2 Right-click Computer.

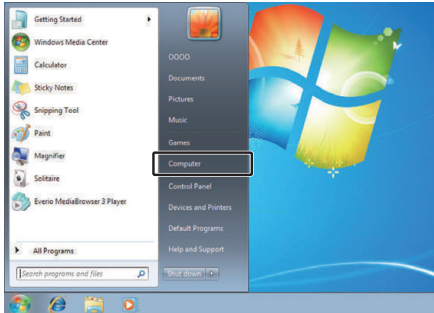

3 Click "Properties".

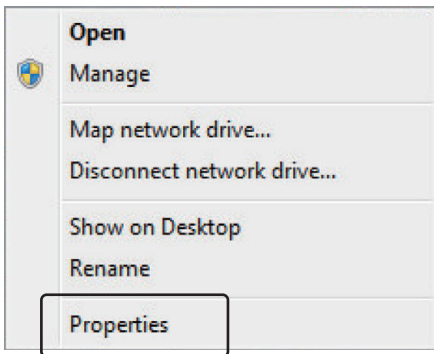

4 Check the system information.

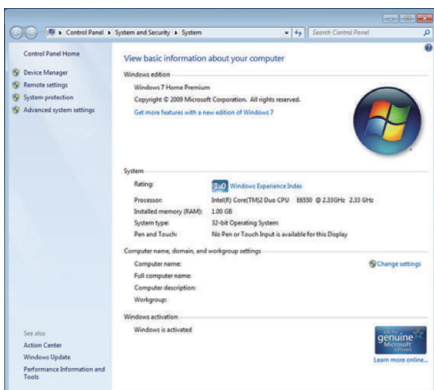

Dubbing Files to a Disc by Connecting to a Blu-ray Recorder

Videos recorded in the HD quality can be dubbed in the high-definition quality by connecting an AVCHD-compliant Blu-ray recorder to this unit via a USB cable. For details on creating the disc, refer to the instruction manual of your Blu-ray recorder.

- 1 Open the terminal cover.
- 2 Insert the SD card to be dubbed.
 - Before inserting the SD card, close the LCD monitor and turn off the power of this unit.
 - Insert only one SD card. Even when two cards are inserted, the Blu-ray recorder only recognizes one SD card.
- 3 Connect to a Blu-ray recorder.
 - Connect using a USB cable (sold separately).

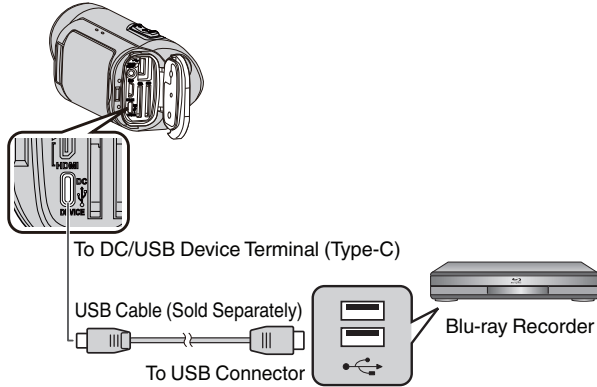

- 4 Open the LCD monitor.

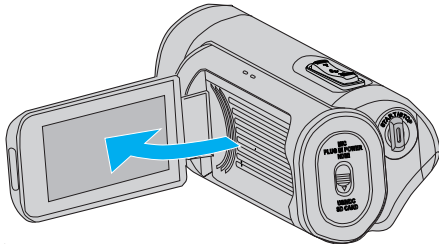

- The power of this unit turns on, and a USB mode screen appears.

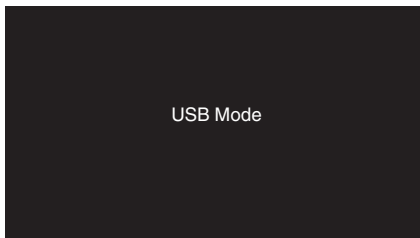

- 5 Perform dubbing on the Blu-ray recorder.
 - Refer also to the instruction manual of the Blu-ray recorder.
 - After dubbing is complete, close the LCD monitor of this unit and check that the POWER/ACCESS lamp goes off before disconnecting the USB cable. Operations cannot be performed on this unit until the USB cable is disconnected.

Memo :

- To save videos that are recorded with “Frame Rate” set to “50p”/“60p”, use an AVCHD Progressive-compatible Blu-ray recorder.

Caution :

- Videos recorded in the 4K or High-Speed quality cannot be saved to a Blu-ray recorder.
- Videos that are recorded with “Frame Rate” set to “50p”/“60p” cannot be saved to a DVD.
- This operation cannot be completed if the remaining battery power is not enough. Charge the battery fully first.

Wi-Fi Capabilities

The Wi-Fi function is able to function by attaching a wireless LAN adapter (sold separately) to the USB host terminal of the camera unit. It comes with a browser-based function that makes use of devices such as smartphones, tablet terminals and PCs, as well as a live streaming function.

■ Wireless LAN adapter (operation verified): TP-LINK: TL-WN725N

- This unit is not guaranteed to operate with all wireless LAN adapters.
- The terminal cover cannot be closed properly when the dimensions of the wireless LAN adapter in use are larger than those indicated in the diagram.

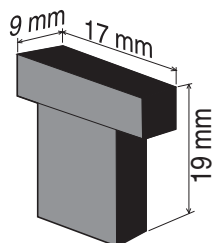

When there is difficulty in removing the wireless LAN adapter: — Use objects such as by tying a string around the wireless LAN adapter to remove it.

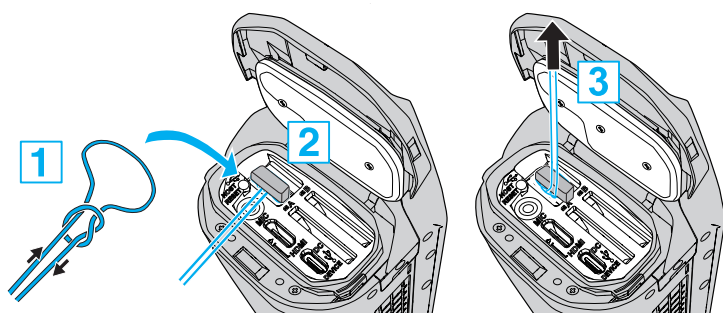

- If the string tends to slip off easily, use tools such as tweezers to insert the string.

List of Functions

■ Browser-based Functions (Web Functions)

- Still Image Transmission

Transfers (downloads) still images stored in the SD card to devices such as a smartphone, tablet terminal or PC.

“Still Image Transfer” (☞ p. 86)

- View Remote

It is possible to access the camera via a web browser on devices such as a smartphone, tablet terminal or PC to check the live image and remotely control the camera.

“View Remote” (☞ p. 90)

■ Live Streaming Function

By combining the camera with a decoder or PC application that supports live streaming, audio and video streaming can be performed via the network.

“Live Streaming” (☞ p. 95)

Precautions on Using Wi-Fi

Cautions on Wi-Fi Function

- Operation is not guaranteed on all devices.
- This function is not designed for disaster or crime prevention.
- Security of Wireless LAN
An advantage of wireless LAN is that instead of using a LAN cable, it transmits information using radio waves, thus enabling LAN connection to be established within the area covered by the radio waves. However, as radio waves penetrate through objects (such as walls) within the range that they cover, security issues, such as interception of transmission or illegal access, may arise if security settings are not configured. Before you connect to the network in a wireless LAN environment, read through the instruction manual for the wireless LAN device in use, and configure the security settings accordingly. Failure to do so may increase the risk of personal information being intercepted, such as user names, passwords, and the content of your mails, or illegal access to the network.
- Due to the design of wireless LAN, note that security may be breached by unusual or unforeseeable means.
- For more details on wireless LAN and network security, please consult the manufacturer of your wireless LAN device.
- JVC shall not be liable for any security issues, troubles, damages or losses arising from the use of this feature.
- Wi-Fi function is not available underwater.

■ Do not use this product near the following places.

- Industrial, scientific, or medical equipment, such as microwave ovens and pacemakers
- Industrial, scientific, or medical equipment, such as microwave ovens and pacemakers
- Specified low-power radio stations (radio station license not required)
- Bluetooth devices

Equipment such as the above mentioned devices makes use of the same frequency bandwidth as that of Wi-Fi.

Using this product near the above equipment may cause radio wave interference, and result in communication failure or a drop in communication speed. In this case, turn off the power of devices that are not in use.

■ Avoid using this product near a TV or radio set.

TV or radio sets make use of a radio wave frequency bandwidth that is different from that of Wi-Fi, and therefore has no effect on communication by this product or the TV/radio set.

However, when a TV/radio set is placed close to a Wi-Fi product, electromagnetic waves emitted by the Wi-Fi product may cause noise to occur in the sound or images of the TV/radio.

- Communication may not be carried out properly near radio equipment or broadcasting stations. In this case, change the location accordingly.

■ Radio signals are unable to penetrate through reinforced steel, metal, or concrete.

The radio waves used by the wireless LAN adapter are unable to penetrate reinforced steel, metal, or concrete materials.

Communication may be adversely affected if the walls of the room are made of any of these materials. Similarly, communication may be compromised if the same materials are used between the floors of a building.

*Communication may also get weaker when there are human subjects or parts of the body in between the Wi-Fi devices.

■ Do not connect to wireless networks that you do not have authorization for.

Once connected, it may be considered as unauthorized access and legal actions can be taken against you.

■ Do not use the Wi-Fi function outside the country where the wireless LAN adapter is purchased.

Depending on the country, there may be restrictions on the use of radio waves and any violations could be punishable by law.

Exporting/Bringing the Unit Overseas

Permission from the U.S. government may be required when bringing the unit to an export controlled country set by the U.S. government (such as Iran, Sudan, North Korea, Syria and Cuba. As of September, 2017). For more information, consult the U.S. Embassy Commercial Service.

How to Establish a Wi-Fi Connection

“Ways of Wi-Fi Connection” (☞ p. 78)

“Preparing for Connection” (☞ p. 79)

“Connecting” (☞ p. 79)

Ways of Wi-Fi Connection

There are three ways of connecting the camera to devices such as a smartphone, tablet terminal or PC.

Direct Connection

- The camera can be connected to devices such as a smartphone, tablet terminal or PC directly via Wi-Fi.

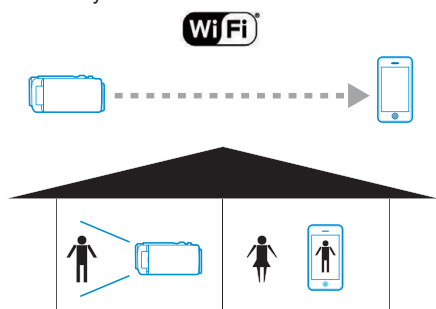

Local Area Network (LAN) Connection

- The camera can be connected to devices such as a smartphone, tablet terminal or PC within the same Local Area Network (LAN).

“What is Local Area Network (LAN)?” (☞ p. 78)

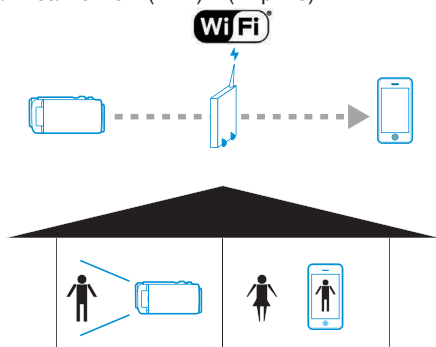

* An access point (wireless LAN router) is needed for this mode of connection.

“What is an access point?” (☞ p. 78)

Internet Connection

- The camera can be connected to devices such as a distant smartphone, tablet terminal or PC via the Internet.



* An Internet connection with a global IP address and an access point (wireless LAN router) that is compatible with UPnP are needed for this mode of connection.

“What is global IP address?” (☞ p. 78)

“What is UPnP?” (☞ p. 78)

“What is an access point?” (☞ p. 78)

Network-related Terminology

■ What is an access point?

An access point refers to a device that makes use of Internet connections wirelessly.

Some common examples include wireless LAN routers and Wi-Fi routers, which come with a function for sharing a single connection among multiple devices.

For Internet connections such as fiber-optic Internet and cable TV that are connected wirelessly, a wireless LAN router (or devices with a wireless LAN router function, such as a modem) is used.

■ What is Local Area Network (LAN)?

While a wireless LAN router allows multiple devices to make use of a single Internet connection, it is possible for devices that are connected to the same wireless LAN router to communicate with one another.

Communication in this case is carried out independently of the Internet connection, and is referred to as a Local Area Network (LAN) connection.

■ What is global IP address?

The Internet connection that we are using either makes use of a global IP address or a local IP address.

A local IP address cannot be accessed from an external source, and thus cannot be used for Internet connections.

If you are unsure of the type of Internet connection that you are using, please consult your Internet service provider.

■ What is UPnP?

UPnP, which is the abbreviation of “Universal Plug and Play”, is a function of wireless LAN routers.

This function can be used to grant limited access from external sources, which is otherwise prohibited.

To find out whether the wireless LAN router in use supports UPnP, please refer to the instruction manual or product catalog of the wireless LAN router. If the UPnP function of a Wi-Fi router can be enabled or disabled, select “Enable”.

Preparing for Connection

Operating Environment

Operation has been verified for the following environments.

■ Computer

- OS: Windows 7
Web browser: Internet Explorer 11
- OS: Windows 10
Web browser: Edge
- OS: Mac OS X
Web browser: Safari 11

■ Smartphone/Tablet Terminal

- OS: iOS11 (iPhone 7)
Web browser: Safari 11
- OS: iOS11 (iPad 5th generation)
Web browser: Safari 11
- OS: Android 7 (Nexus9)
Web browser: Chrome
- OS: Windows 8.1 (Surface)
Web browser: Internet Explorer 11

Preparation on the Camera

■ Attach a wireless LAN adapter to the USB host terminal of the camera

- Only a Wi-Fi connection adapter can be connected to the USB host terminal.
- Connect or disconnect an adapter only after you have turned off the power of the camera recorder.

1 Enable the network connection.

Set "MENU"→"System"→"Network" to "On".

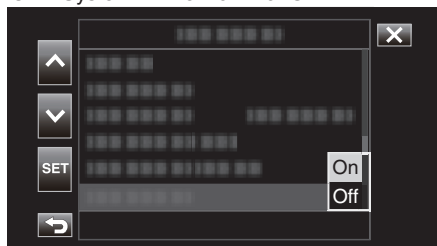

2 Configure the connection settings.

Tap "Settings" that is directly below "Network", select "Connection Setup" and tap "SET".

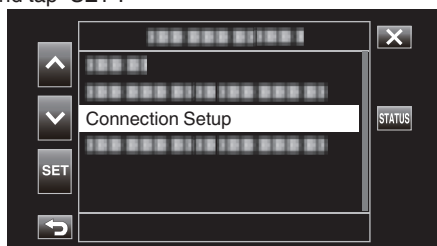

- A wizard screen appears. Follow the instructions on the screen to perform setting.

Connecting

Direct Connection

This mode of connection enables direct access to the web functions of this camera from devices such as a smartphone, tablet terminal or PC.

- 1 (Operation on this camera)
Launch the wizard screen and tap >.

Starting up the wizard screen ("Preparation on the Camera" (p. 79))



- 2 Select "Direct Connection" and tap >.

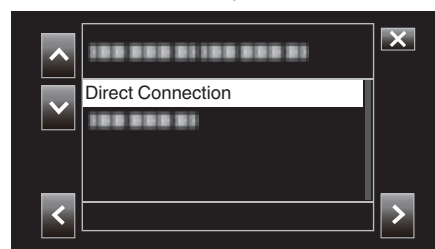

Follow the screen instructions to complete setting. Configure the settings for the following.

- Configuration method
* Configuration of SSID and passphrase in the case of manual configuration.
If there is no need to alter the displayed SSID and passphrase, write down the information and tap the > button.

To proceed to the next step, tap >. To return to the previous step, tap <.

- 3 Tap ✓DONE at the lower right of the screen.

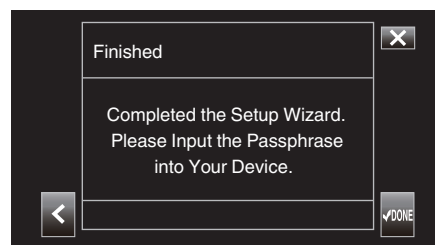

* Screen when "Manual" is selected and configuration is complete.

- When "WPS" is selected on the "Select Setup Type" screen, the following steps 4 and 5 are not required.

- 4 Tap "STATUS".

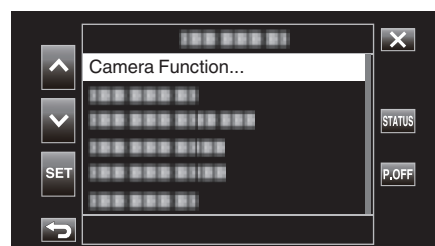

5 Tap <> to display the “Network” screen.

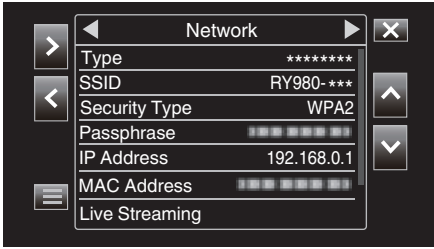

Check to ensure that the “SSID” and “Passphrase” that you have configured in the wizard are displayed.

6 (Operation on a smartphone, tablet terminal or PC)
Display the list of access points in the wireless connection settings and select “RY980-xxxxxx”.

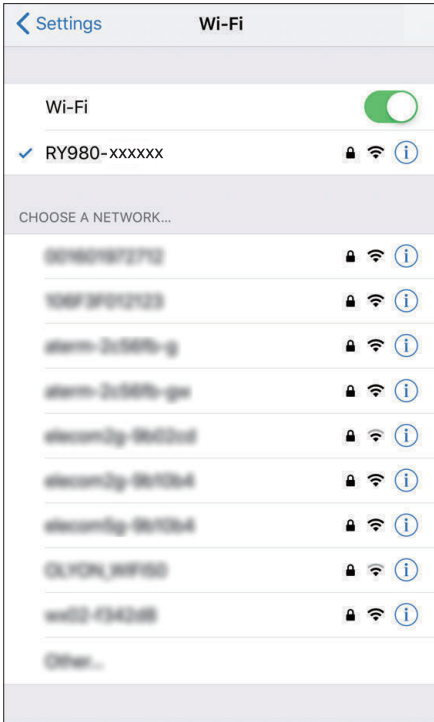

• xxxxx varies with the device used.

7 A password confirmation screen appears.

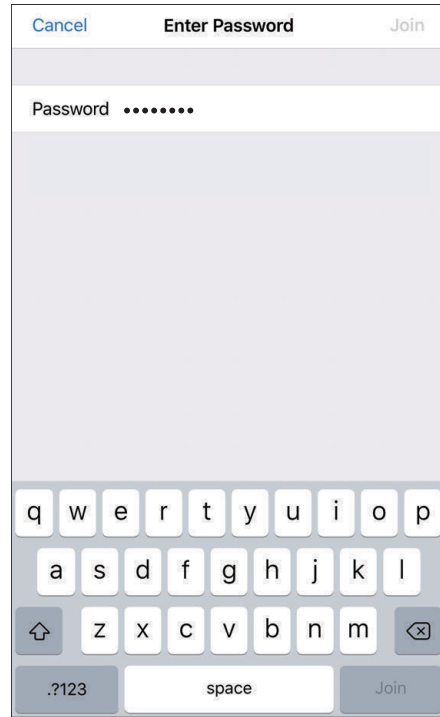

Enter the “Passphrase” displayed on the “Network” screen in Step 5.

Access the camera via a web browser on devices such as a smartphone, tablet terminal or PC

- 1 Display the "MENU"→"STATUS"→"Network" screen.

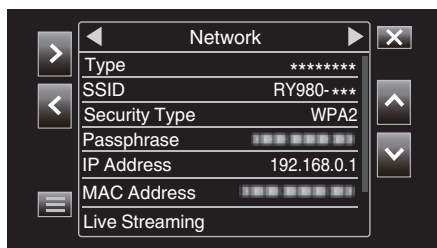

Check the displayed IP address.

- 2 (Operation on a smartphone, tablet terminal or PC) Start up the web browser on the terminal you wish to connect to the camera, enter the "IP Address" that you have verified in Step 1 into the address field and confirm the entry.



- If "192.168.0.1" is displayed in "IP Address", enter "http://192.168.0.1".

- 3 A login screen appears.

Enter the user name (jvc) and password (default value: 0000) and confirm the input.

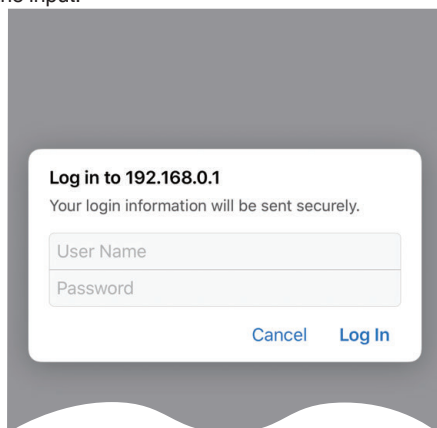

- 4 The main page of the camera is displayed.

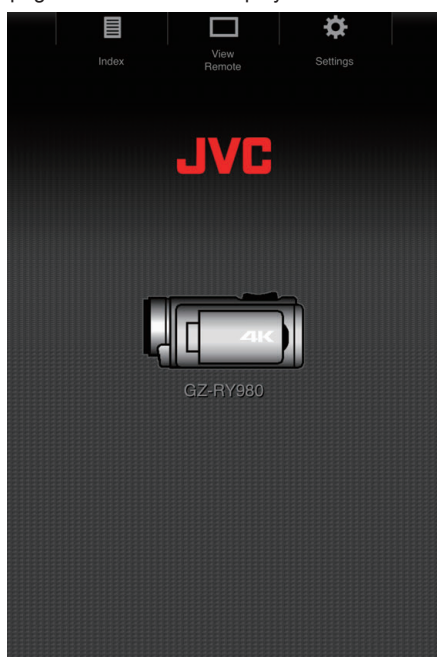

Memo :

- The password can be changed in "MENU"→"System"→"Network"/"Settings"→"Web"→"Login Password".

Connection via an Access Point

Internet Connection

This mode of connection enables access to the web functions of this camera via the Internet from devices such as a smartphone, tablet terminal or PC.

* To use this function, it is necessary to get ready a wireless LAN router compatible with UPnP (Universal Plug and Play) and an Internet connection that allows a global IP address to be acquired.

"What is UPnP?" (☞ p. 78)

"What is global IP address?" (☞ p. 78)

- Use a wireless LAN router that supports UPnP. (Products that come with a Wi-Fi certification logo) To check whether UPnP is supported, please refer to the instruction manual of the wireless LAN router in use.

Memo :

- Depending on the wireless LAN router in use and signal strength, you may experience connection problems or slow connections.
- When operating the zoom function using a smartphone, the response may be slower compared to using the camera.

Obtaining a Dynamic DNS (DDNS) Account

By obtaining a dynamic DNS account, this unit may be used on the web as usual even if the IP address changes when making an access to this unit via the Internet.

- Only the JVC Dynamic DNS service can be configured on this camera. To obtain (register) an account, perform the following steps.

- 1 Access the following URL from a browser and register for a provisional account. (Operation on a PC or smartphone)
<https://dd3.jvckenwood.com/user/>
Set your e-mail address as the user name.
- 2 Check that you have received a confirmation e-mail to the address used for the provisional registration, and access the URL stated in the e-mail. (Operation on a computer or smartphone)
- 3 Check the account information (user name and URL for access (WAN)). Write down the information needed for access.

■ Connection Adapter Settings and Camera Connection

1 Launch the wizard screen and tap >.

“Preparation on the Camera” (☞ p. 79)



2 Select “Connect with Access Point”, followed by tapping >.

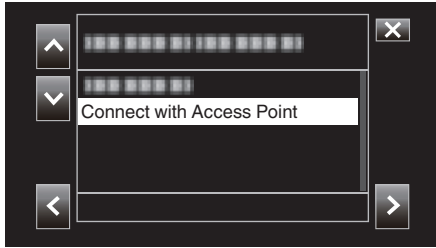

3 Select “Internet connection”, followed by tapping >.

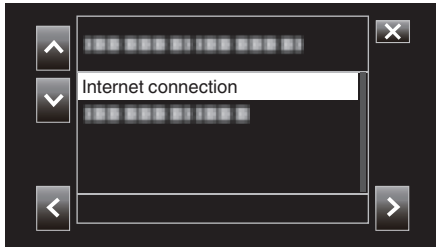

4 Select the method of configuration and tap >. Configure WPS here.

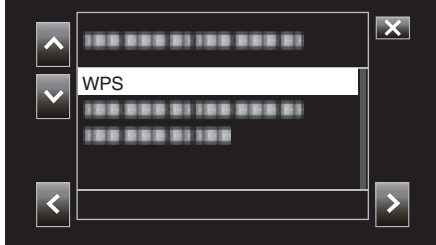

5 Press the WPS button on the access point. For more information, please refer to the instruction manual of the access point.

6 Tap “WPS”.

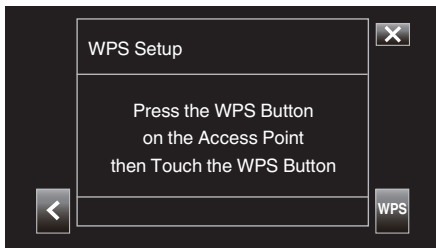

7 A connection successful screen appears.

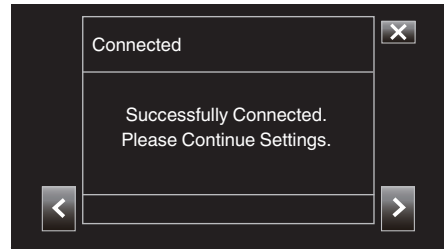

Follow the instructions on the screen to configure “HTTP Port”/“UPnP”/“DDNS”/“Username”/“Password”.

- HTTP Port: Configure the port number for connecting to the Internet. This is usually set to “80”.
- UPnP: Set to “On” if the UPnP protocol can be used to connect the device to the network.
- DDNS: Configure the environment for connecting to the Internet. This is usually set to “On”.
- Username: Configure a user name for the acquired DDNS account.
- Password: Configure a password for the acquired DDNS account.
- For non-WPS, information such as SSID, type of encryption, passphrase and IP address (“DHCP” or “Manual”) also need to be configured.

Memo :

- It is also possible to configure the connection settings in the “Settings” tab after direct connection is established and upon access to the main page of the camera via the web browser. “Changing Connection Settings” (☞ p. 94)

■ Access the camera via a web browser on devices such as a smartphone, tablet terminal or PC

- 1 Check the URL in "MENU"→"STATUS"→"URL(WAN)" of the camera.

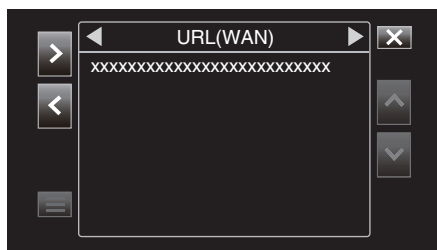

- 2 Start up the web browser on devices such as a smartphone, tablet terminal or PC and access the verified URL.

- 3 Enter the user name and password.

Upon entering the user name (jvc) and password (default value: 0000) on the login screen, the main page of the camera is displayed.

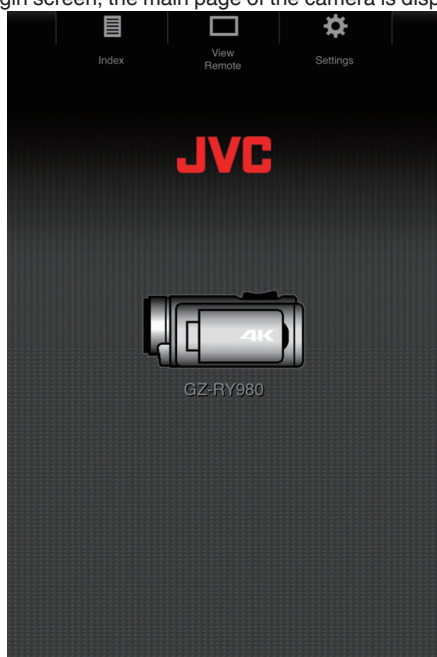

Local Area Network (LAN) Connection

This mode of connection enables access to the web functions of this camera from devices such as a smartphone, tablet terminal or PC that is within the same Local Area Network (LAN).

■ Connection Adapter Settings and Camera Connection

- 1 Launch the wizard screen and tap >.

“Preparation on the Camera” (☞ p. 79)



- 2 Select “Connect with Access Point”, followed by tapping >.

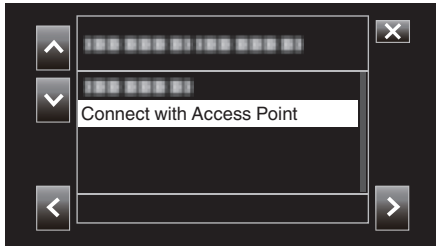

- 3 Select “In-network Connection”, followed by tapping >.

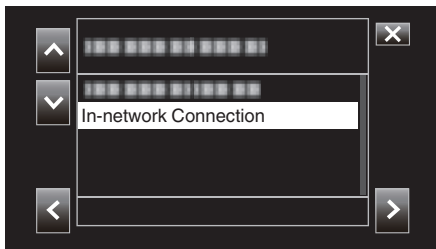

- 4 Select the method of configuration and tap >.

Configure WPS here.

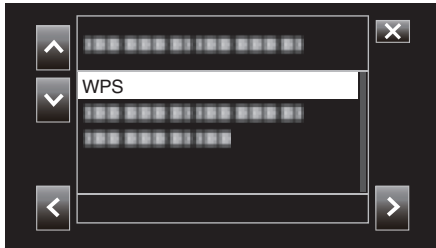

- 5 Press the WPS button on the access point.

For more information, please refer to the instruction manual of the access point.

- 6 Tap “WPS”.

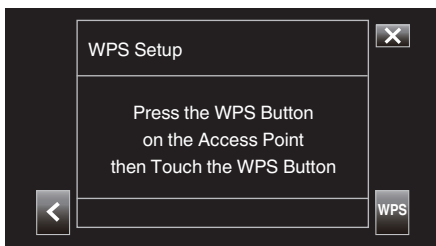

- 7 A connection successful screen appears.

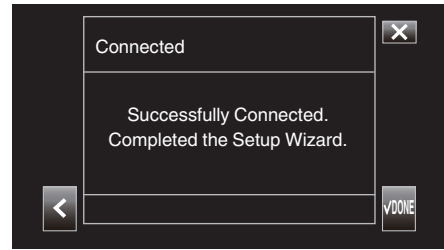

For non-WPS, information such as SSID, type of encryption, passphrase and IP address (“DHCP” or “Manual”) also need to be configured.

Memo :

- It is also possible to configure the connection settings in the “Settings” tab after direct connection is established and upon access to the main page of the camera via the web browser. “Changing Connection Settings” (☞ p. 94)

■ Access the camera via a web browser on devices such as a smartphone, tablet terminal or PC

1 Connect a smartphone, tablet terminal or PC to a Local Area Network.
This setting is not required if the smartphone, tablet terminal or PC is already connected to the Local Area Network.

2 Display the “MENU”→“STATUS”→“Network” screen.

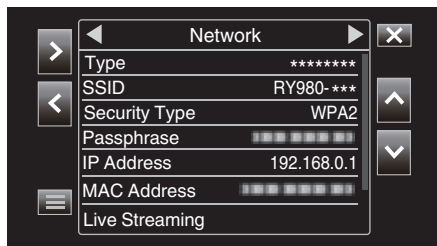

Check the displayed IP address.

3 (Operation on a smartphone, tablet terminal or PC)
Start up the web browser on the terminal you wish to connect to the camera, enter the “IP Address” that you have verified in Step 2 into the address field and confirm the entry.



- If “192.168.0.1” is displayed in “IP Address”, enter “http://192.168.0.1”.

4 A login screen appears.

Enter the user name (jvc) and password (default value: 0000) and confirm the input.

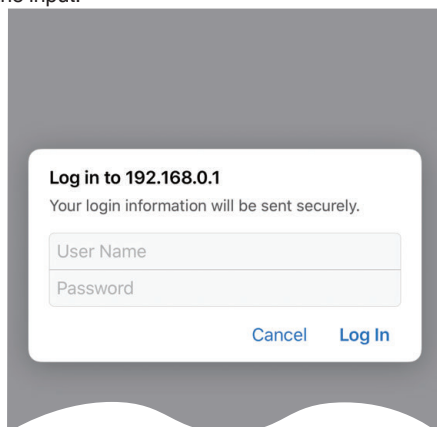

5 The main page of the camera is displayed.



Memo :

- The password can be changed in “MENU”→“System”→“Network”/“Settings”→“Web”→“Login Password”.

Still Image Transfer

This function transfers (downloads) still images stored in the SD card of the camera to a smartphone, tablet terminal or PC. Multiple or all still images can be downloaded at a time.

Caution :

- iOS devices do not allow multiple image data to be downloaded all at once.
- Also, disable the Pop-up block in the Safari settings of iOS devices.

■ When Multiple Files Can be Selected

- 1 Access the main page of the camera via the web browser of devices such as a smartphone.

The method of operation varies with the mode of connection.
 "Direct Connection" (p. 79)
 "Internet Connection" (p. 81)
 "Local Area Network (LAN) Connection" (p. 84)

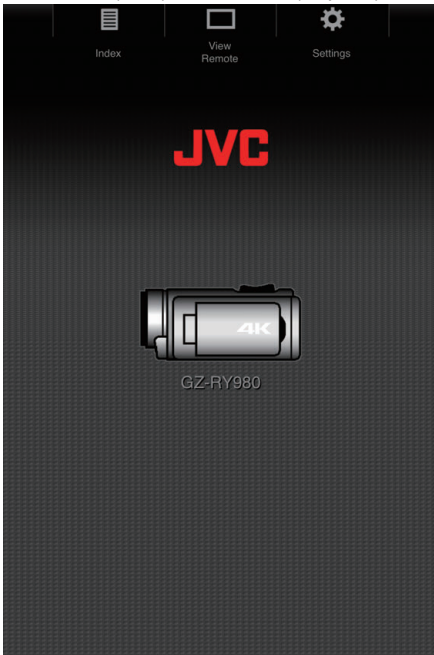

- 2 Tap (click) "Index".

The following screen is displayed.

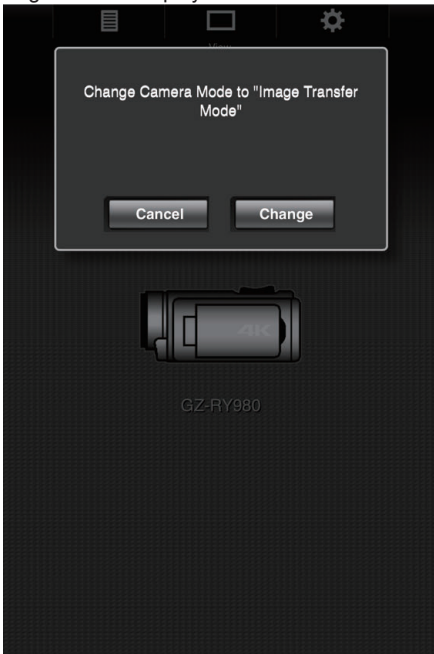

At the same time, the screen below also appears on the LCD monitor screen of the camera.

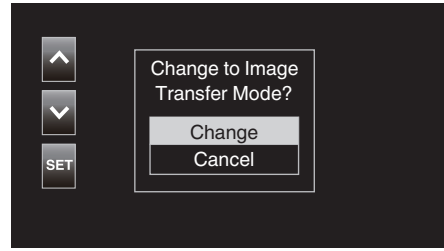

- 3 Tap (click) "Change" on the web browser screen or select "Change" on the camera and tap SET.

An index screen (data list) of the still images stored in the SD card of the camera is displayed on the browser.

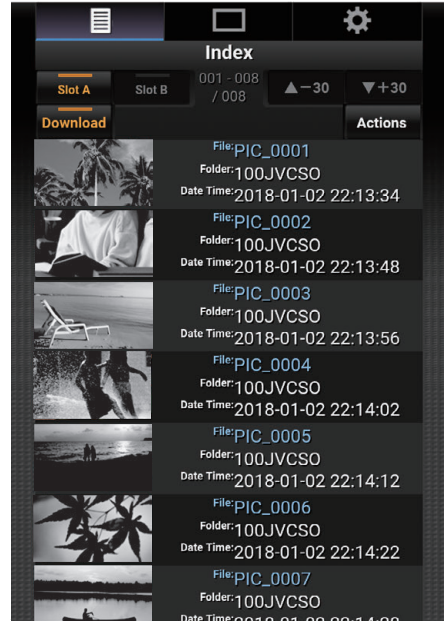

Memo :

- To download all files or files that are protected, Step 4 below is not needed.

4 Tap (click) the still images to download.

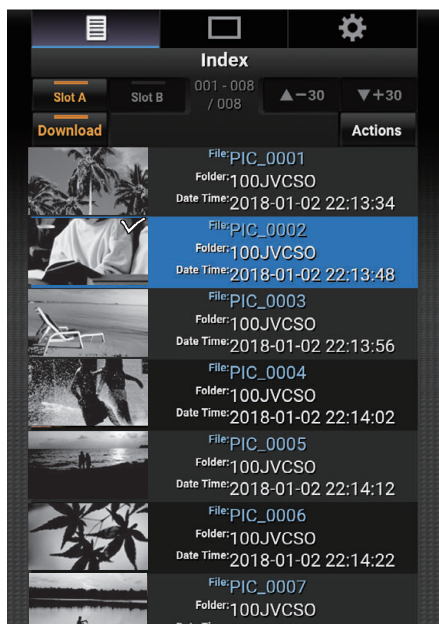

- When an SD card is inserted into both Slot A and Slot B, tapping (clicking) Slot A or Slot B switches the display to the list of the corresponding slot.
- Up to 30 titles are displayed on each page of the list. Tapping (clicking) “▲-30” displays the previous page, while tapping (clicking) “▼+30” displays the next page.

A check mark is appended to each of the selected files. Multiple files can be selected.

5 Tap (click) “Action”.

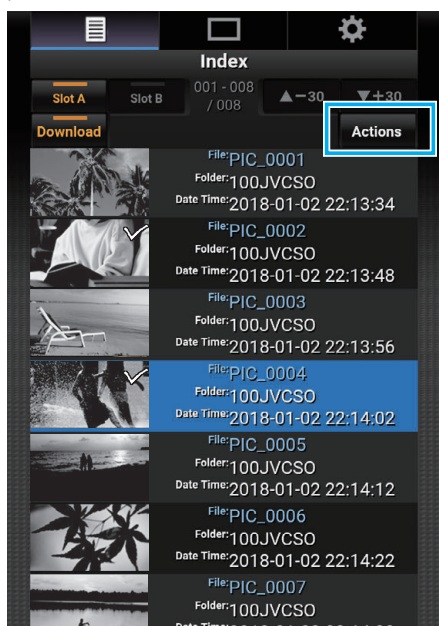

Memo :

- If there is no data on the index screen, “Action” is grayed out and cannot be selected.

6 Select the method to transfer the files.

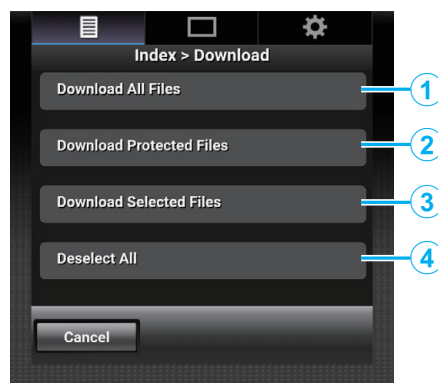

①	Download All Files	Downloads all the files in the displayed slot.
②	Download Protected Files	Downloads all protected files in the displayed slot.
③	Download Selected Files	Downloads the selected files.
④	Deselect All	Clears all file selections and returns to the index screen.

To cancel the operation, tap (click) “Cancel” to return to the index screen.

- If the files to transfer are not selected, “Download Selected Files” and “Deselect All” are grayed out and cannot be selected.

Tapping (clicking) a transfer method starts the transfer process.

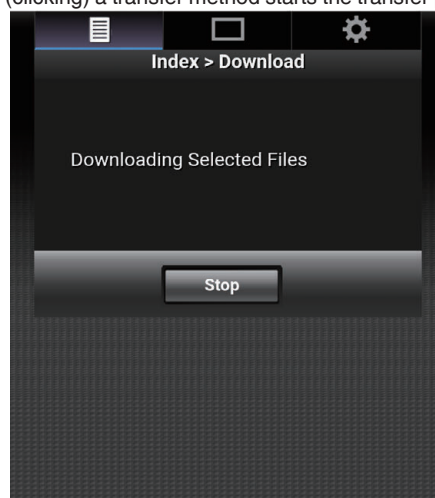

- To cancel the download, tap (click) “Stop”, followed by tapping (clicking) “Yes” when “Stop Downloading?” appears.

- 7 After transfer is complete, a transfer complete screen is displayed.

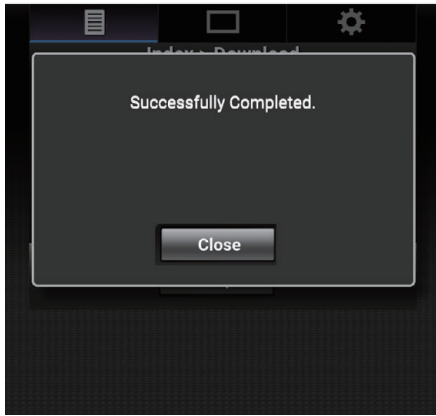

Tap (click) "Close" to end still image transfer and return to the main screen.

■ When Multiple Files Cannot be Selected

- 1 Access the main page of the camera via the web browser of devices such as a smartphone.

The method of operation varies with the mode of connection.

"Direct Connection" (p. 79)

"Internet Connection" (p. 81)

"Local Area Network (LAN) Connection" (p. 84)

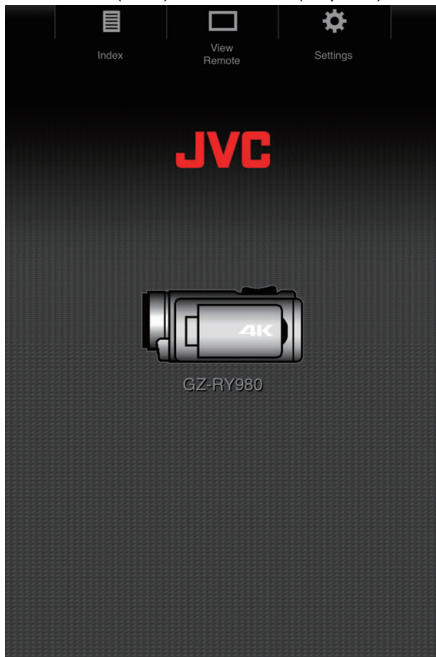

- 2 Tap (click) "Index".

The following screen is displayed.

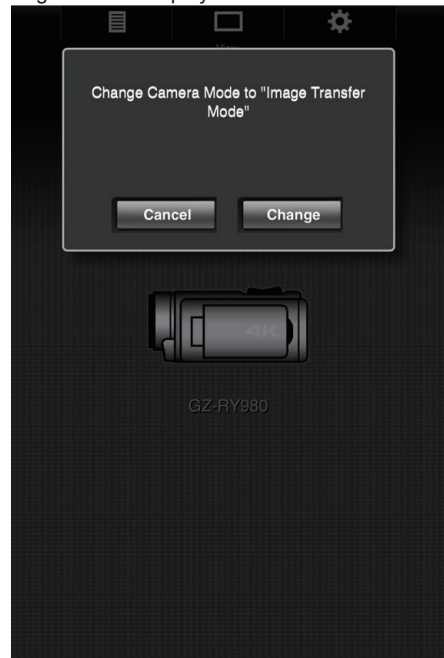

At the same time, the screen below also appears on the LCD monitor screen of the camera.

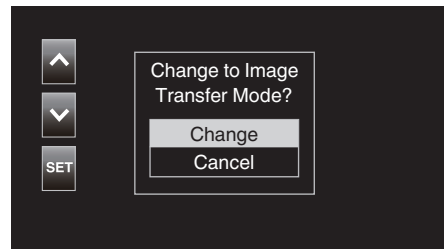

- 3 Tap (click) "Change" on the web browser screen or select "Change" on the camera and tap SET.

An index screen (data list) of the still images stored in the SD card of the camera is displayed on the browser.

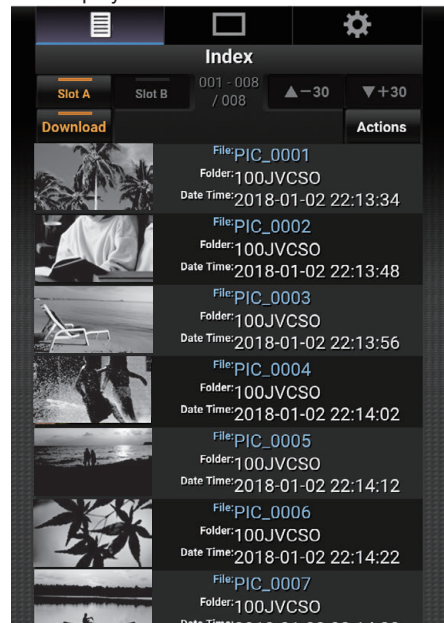

- 4 Select the still image data to download one by one and tap (click) them.

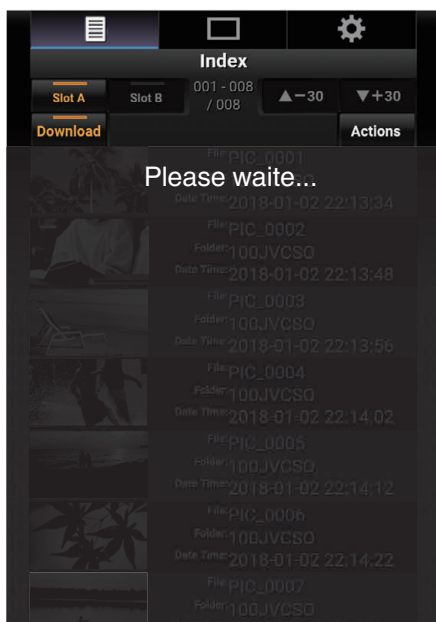

A new tab appears on the browser. Operate according to the instructions on the browser.

Caution :

- The browser cannot be operated by tapping (clicking) “View Remote” or “Settings” while download is in progress.
- The browser cannot be operated during live streaming.

Memo :

- When “View Remote” is tapped (clicked) while the index screen is displayed, the “View Remote” screen appears. Also, the screen display on the camera switches from the “Image Transfer Mode” display to the recording standby screen.
- When “Settings” is tapped (clicked) while the index screen is displayed, the “Settings” screen appears. Also, the screen display on the camera switches from the “Image Transfer Mode” display to the recording standby screen.

View Remote

It is possible to access the camera via a web browser on devices such as a smartphone, tablet terminal or PC and perform remote operations such as checking the live image, starting or stopping recording, zooming in or out, and operating the menu.

- 1 Access the main page of the camera from the web browser of devices such as a smartphone, followed by tapping (clicking) "View Remote".

The method of operation varies with the mode of connection.

"Direct Connection" (p. 79)

"Internet Connection" (p. 81)

"Local Area Network (LAN) Connection" (p. 84)

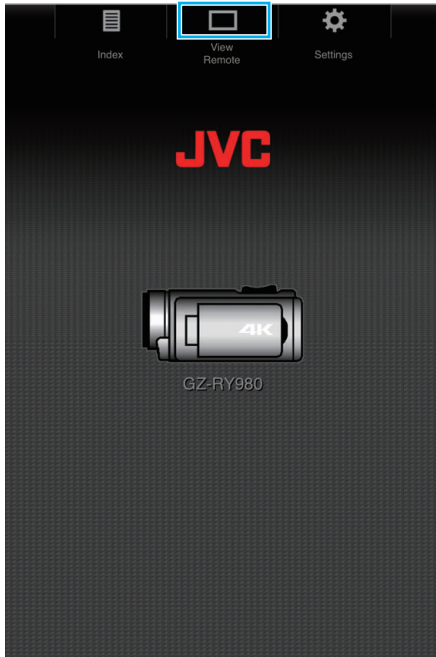







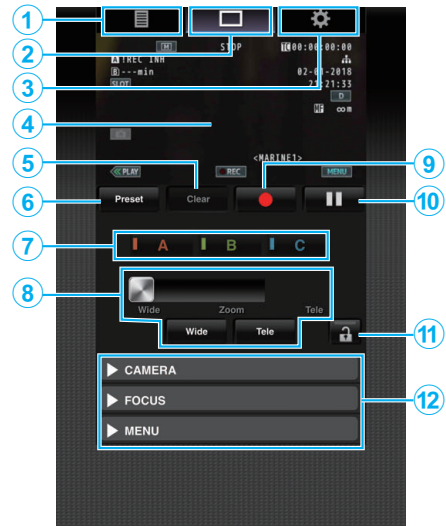

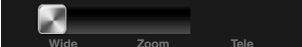
The "View Remote" screen is displayed.

Operating Procedure

"View Remote" Screen



No.	Tab	Function						
①	Index	Displays the "Index" screen.						
②	View Remote	Displays the "View Remote" screen.						
③	Settings	Displays the "Settings" screen.						
④	Recording Screen	Displays the same screen as the live image on the camera. Icons on the screen are displayed or hidden in tandem with those on the camera.						
⑤	"Clear" Button	Switches to the Delete Preset Zoom Position mode.						
⑥	"Preset" Button	Switches to the Register Preset Zoom Position mode.						
⑦	"A"/"B"/"C" Buttons	Use these buttons to perform preset registration or delete a preset data.						
⑧	Zoom Control	<ul style="list-style-type: none"> Operate the zoom function by dragging the zoom button along the sliding bar. Tap (click) the "Wide" or "Tele" button to fine-tune the zoom position. The slide changes according to the dynamic zoom and digital zoom. Dynamic Zoom Off:  Dynamic Zoom On:  Digital zoom On: 						
⑨	Recording Start Button	Start recording.						
⑩	Recording Stop Button	Stops recording.						
⑪	Function Lock Button	Locks the functions that have been set on the "Settings" screen. <table border="1" data-bbox="1077 1780 1508 1937"> <thead> <tr> <th>Icon</th> <th>Description</th> </tr> </thead> <tbody> <tr> <td></td> <td>Activates the lock.</td> </tr> <tr> <td></td> <td>Does not activate the lock.</td> </tr> </tbody> </table>	Icon	Description		Activates the lock.		Does not activate the lock.
Icon	Description							
	Activates the lock.							
	Does not activate the lock.							
⑫	Camera Control Function	The camera can be controlled by accessing it from a web browser on devices such as a smartphone, tablet terminal or PC. Operation can be performed for each of the items.						

Registering/Deleting Preset Zoom

■ Registering Preset Zoom

Up to 3 zoom positions can be registered.

- 1 Tap (click) "Preset".

Switches to the Register Preset Zoom Position mode.



- 2 Operate the zoom bar or "Wide" and "Tele" to determine the zoom position.



- 3 Tap (click) "A".

Position "A" is registered and displayed on A of the zoom control sliding bar.



- 4 In the same way, register positions "B" and "C".

After all three positions A, B and C are registered, the positions of the "A", "B" and "C" buttons will be rearranged according to the order of the registered zoom position starting from the left.



5 Tap (click) "Preset".

Exits the Register Preset Zoom Position mode.



Memo :

- After registration is complete, tapping (clicking) each button switches to the corresponding preset zoom position.
- The preset button where the dynamic zoom position is registered when the dynamic zoom is on grays out when the dynamic zoom is off and the zoom position cannot be changed.
- When the dynamic zoom is off, the dynamic zoom position cannot be registered.
- When digital zoom is on, the preset button where the digital zoom position is registered grays out when digital zoom is off and the zoom position cannot be changed.
- When digital zoom is off, the digital zoom position cannot be registered.

■ **Deleting a Preset Zoom**

Cancels the preset zoom registered in all or any of the buttons "A", "B" and "C".

1 Tap (click) "Clear".

Switches to the Delete Preset Zoom Position mode.



2 Tap the position to delete ("A"/"B"/"C").

If "A" is tapped (clicked), the position registered to A is deleted and the button grays out. The corresponding zoom position mark on the sliding bar also disappears.

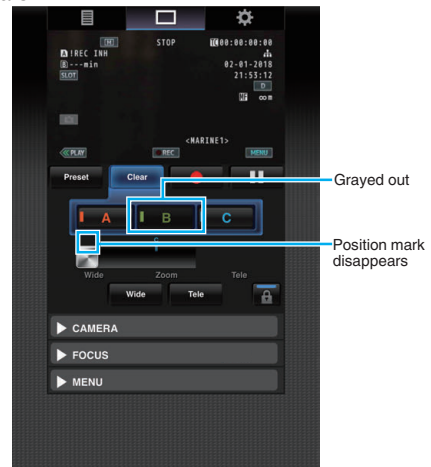

3 Tap (click) "Clear".



Exits the Delete Preset Zoom Position mode.

Memo :

- This function is available only in the recording mode.
- It does not support audio.
- Recorded images are not displayed during live streaming.
- The possible remote operations are as follows.

CAMERA

- Switching between the Auto and Manual modes
- Configuration of brightness level (BRIGHTNESS ADJUST)
- Configuration of aperture (APERTURE)
- Configuration of gain up level (GAIN UP)
- Configuration of shutter speed (SHUTTER)
- Configuration of white balance (WHITE BALANCE)

FOCUS

- Adjustment of focus

MENU

- Switching of TV display (DISPLAY ON TV)
Operates in tandem with the View Remote recording screen.
- Menu operation
- Switching of STATUS display
It is possible to switch between menus when a menu is displayed.
- Operation lock

Changing the Settings via a Web Browser

You can change the network-related settings by accessing via a web browser on devices such as a smartphone, tablet terminal or PC.

1 Access the main page of the camera via the web browser of devices such as a smartphone.

The method of operation varies with the mode of connection.

“Direct Connection” (☞ p. 79)

“Internet Connection” (☞ p. 81)

“Local Area Network (LAN) Connection” (☞ p. 84)

2 Tap (click) the “Settings” tab.



3 The “Settings” screen appears.

Set each of the items as follows.

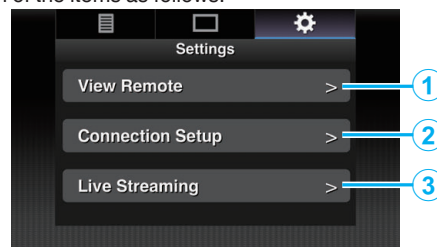

No.	Item	Description
①	View Remote	Settings for operations on the View Remote.
②	Connection Setup	Settings related to the network. The settings for each of the preset items on the wizard screen of the camera can be changed directly.
③	Live Streaming	Settings for streaming audio and video via the network. The latest settings are reflected, regardless of whether they are specified via the camera recorder or web operation.

Memo :

- Priority is given to menu operation on the camera.
- When the menu on the camera is opened while the “Settings” screen is displayed on a web browser, a warning appears, after which the display returns to the main screen.
- While the menu is displayed on the camera, the “Settings” screen cannot be opened via the web browser.

■ Changing Settings of the View Remote Function

For performing setting for using the View Remote function.

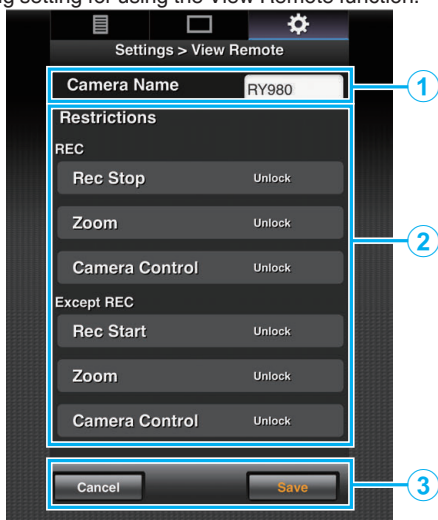

No.	Item	Description
①	Camera Name	For configuring a camera name such as one that differentiates the camera to connect from other cameras.
		Tapping (clicking) the text input area displays a software keyboard. If you are using a PC, enter using the PC keyboard.
		By tapping (clicking) the Go key after input is complete, the software keyboard disappears.
②	Access Restriction	For setting the buttons to be disabled on the View screen while in the locked mode. “REC”: For configuring whether to disable the Sop Recording button, zoom operation and camera control in the recording mode. Tap (click) each item to switch between “Unlock” and “Lock”.
		“Except REC”: For configuring whether to disable the Record button, zoom operation and camera control in modes other than the recording mode. Tap (click) each item to switch between “Unlock” and “Lock”.
③	Save/Cancel	Tap (click) “Save” to save the settings.
		Tap (click) “Cancel” to stop configuration and return to the main “Settings” screen.

■ Changing Connection Settings

The settings for each of the preset items on the wizard screen of the camera can be changed directly.

- If all the items cannot be displayed in a single page, scroll down to display the remaining items.
- Items that cannot be changed are grayed out according to the mode of connection.



No.	Item	Description
①	Mode of Wireless LAN Connection	“Direct Connection” (☞ p. 79) “Internet Connection” (☞ p. 81) “Local Area Network (LAN) Connection” (☞ p. 84)
②	“Search Access Point” Button	Tap (click) to display a list of the detected access points. A check mark (●) appears at the beginning of the access point that is currently selected. Caution : • “No Access Points” appears during direct connection and the access point cannot be selected.
③	Settings	For configuring settings such as SSID and passphrase.
④	“OK”/ “Cancel” Button	After changing of settings is complete, tap (click) the “OK” button.
		On the confirmation screen, tap (click) “Execute” to change the settings on the camera and restart the network.

■ Changing Streaming Settings

You can make direct changes to information on the destination of distribution that is configured in “MENU”→“System”→“Network”/“Settings”→“Live Streaming Set”.

“Live Streaming” (☞ p. 95)

Live Streaming

This is a function for distributing camera images to servers via the network. By combining the camera with a decoder or PC application that supports live streaming, audio and video streaming can be performed via the network.

Memo :

- A distribution protocol can be selected from MPEG2-TS/UDP, MPEG2-TS/RTP, RTSP/RTP and RTMP.

Supported Formats

Video: H.264

- 1920x1080:
50i/60i (12.0 Mbps), 50i/60i (8.0 Mbps), 50i/60i (5.0 Mbps),
50i/60i (3.0 Mbps)
- 1280x720:
25p/30p (8.0 Mbps), 25p/30p (5.0 Mbps), 25p/30p (3.0 Mbps),
25p/30p (1.5 Mbps)
- 640x360:
25p/30p (3.0 Mbps), 25p/30p (1.5 Mbps), 25p/30p (0.8 Mbps),
25p/30p (0.3 Mbps)

Audio: AAC

Memo :

- The following restrictions are applicable depending on the settings of "MENU"→"MENU"→"System"→"MENU"→"Network"/"Settings"→"MENU"→"Live Streaming Set"→"MENU"→"Streaming Server"→"MENU"→"Server"→"MENU"→"Type". ("Server" is the name configured for the destination server.)
- * An encoding bit rate exceeding 8 Mbps cannot be selected when the transmission mode is configured to MPEG2-TS/RTP or RTSP/RTP, and a bit rate exceeding 5 Mbps cannot be selected in the RTMP mode.
- * Depending on the type of network adapter used and the connection, images and audio sound during live streaming may be choppy.

Supported Protocols

Network protocols:

TCP, UDP

Transport mode:

MPEG2-TS/UDP, MPEG2-TS/RTP, RTSP/RTP, RTMP

Distribution Settings

- 1 Configure "Record Format" according to the resolution and frame rate of the video to be distributed.
Configure the settings in "MENU"→"System"→"MENU"→"Record Set"→"MENU"→"Record Format".
For more details on the "Record Format" settings, please refer to the following.
"Combinations of "Record Format" and "Live Streaming" that Support Transmission" (p. 95)
- 2 Configure the resolution and frame rate/image quality of the video to be distributed.
Configure the settings in "MENU"→"System"→"Network"/"Settings"→"Live Streaming Set".
- 3 Specify the distribution protocol and related items.
Configure the distribution protocol and related settings in "MENU"→"System"→"Network"/"Settings"→"Live Streaming Set"→"Streaming Server".
- 4 Select the server for live streaming.
Select the distribution server in "MENU"→"System"→"Network"/"Settings"→"Live Streaming Set"→"Server".

Memo :

- Live streaming does not function when "MENU"→"System"→"Record Set"→"Record Format"→"System" is set to "4K" or "High-Speed".
- Live streaming operation cannot be performed during recording. To record while performing live streaming, stop the recording once, start the live streaming operation, followed by starting the recording again.

Combinations of "Record Format" and "Live Streaming" that Support Transmission

Record Format				Live Streaming (Resolution, number of frames)		
System	Resolution	Frame Rate	Bit Rate	1920x1080, 50i/60i	1280x720, 25p/30p	640x360, 25p/30p
4K	-	-	-	x	x	x
HD		50p/60p	28M	○	○	○
		50i/60i	24M/ 18M	○	x	○
High-Speed	-	-	-	x	x	x

○: Supported; x: Not supported

Starting Distribution

- 1 Perform the necessary setting for the decoder and PC application.
For more details on the settings, please refer to the instruction manual of the respective devices and applications.

Memo :

- If there are devices such as a NAT router within the communication path between the camera and the decoder, port forwarding setup is required. For more details on the settings, please refer to the instruction manual of the router in use.
- The following setting values are required when connecting to this camera using RTSP/RTP.
Port number: 554
Stream ID: stream
- Use the following to access via URL.
Rtsp://<IP address of the camera>:554/stream

- 2 Connect the camera to the network via Wi-Fi.

“Preparing for Connection” (p. 79)

- 3 Set “Live Streaming” to “On”.

Set “MENU”→“System”→“Network”/“Settings”→“Live Streaming Set”→“Live Streaming” to “On”.

- The network connection mark appears on the LCD monitor screen when a network connection is established.

“Network Connection” (p. 128)



Memo :

- You can view the status of distribution on the LCD monitor.

Icon	Status
LIVE (Red)	Distribution in progress (good connection quality) Blinks when distribution starts or stops
LIVE 🗨️ (Red)	Distribution in progress (poor connection quality)
LIVE 🗨️ (Yellow)	Waiting for connection (during RTSP/RTP) or connection failed

- When 🗨️ is displayed, the error description is displayed on the “STATUS”→“Network” screen.

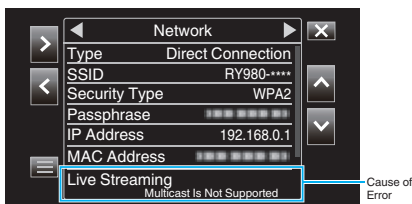

Caution :

- Streaming may be interrupted temporarily 24 hours after the process started.

Operating the Menu

The following menu is available on this unit.

- Camera Function Menu
For configuring the camera operation during recording (e.g., image stabilizer).
- Camera Process Menu
For configuring settings related to image quality adjustment during recording.
- TC Menu
For configuring the time code.
- Monitor Menu
For configuring settings related to the LCD monitor display.
- A/V Set Menu
For configuring settings related to audio and video output.
- System Menu
For configuring the general settings of the camera, such as recording format and clock.

Operating the Menu

You can configure various settings using the menu.

- 1 Tap "MENU".



- The main menu appears.

- 2 Select the desired item from the menu and tap the "SET" button.

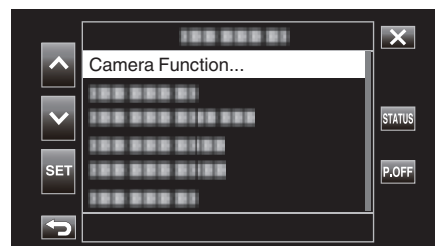

- STATUS:
Displays the screen for checking the current settings.
- P.OFF:
Pressing the button for approximately 2 seconds or longer turns off the power.

- 3 Select the item to be configured.

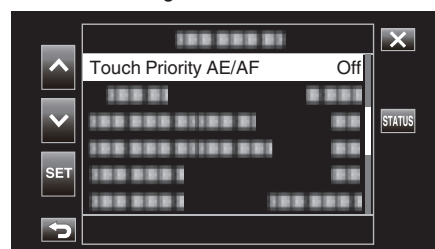

- Use ^ and v to scroll up and down.
- Tap "SET" to confirm the selection.

Memo :

- To select an item
Tap ^, v, < and >.
- To confirm selection
Tap "SET".
- To return to the previous screen
Tap ↶.
- To exit the screen
Tap X (quit).

Main Menu

Camera Function

For configuring the camera operation during recording (e.g., image stabilizer).
“Camera Function Menu” (☞ p. 99)

Caution :

- The camera functions are not available for selection during recording with “System” set to “High-Speed”.
-

Camera Process

For configuring settings related to image quality adjustment during recording.
“Camera Process Menu” (☞ p. 101)

TC

For configuring the time code.
“TC Menu” (☞ p. 106)

Monitor

For configuring settings related to the LCD monitor display.
“Monitor Menu” (☞ p. 107)

A/V Set

For configuring settings related to audio and video output.
“A/V Set Menu” (☞ p. 112)

System

For configuring the general settings of the camera, such as recording format and clock.
“System Menu” (☞ p. 114)

Camera Function Menu

Touch Priority AE/AF

Automatically adjusts focus and brightness based on the subjects' faces or selected area.

"Capturing Subjects Clearly (TOUCH PRIORITY AE/AF)" (☞ p. 38)

Caution :

- Touch Priority AE/AF cannot be selected in the following cases.
 - When "Focus" is set to "Manual"
 - When "System" is set to "High-Speed"
 - When "Rec Mode" is set to "Time-Lapse Rec"
- When all of "Shutter Speed", "Aperture" and "Gain Up" are set to "Manual", "AreaSel" cannot be selected.
- FaceDet cannot be selected in the following cases.
 - When "Backlight Comp" is set to "On"
 - When "Lolux" is set to "On"

Video Self Timer

For configuring the self-timer for videos.

"Using Video Self Timer" (☞ p. 45)

Caution :

- Video Self Timer cannot be selected in the following cases.
 - During recording
 - When "Rec Mode" is set to "Pre Rec" or "Time-Lapse Rec"

Still Self Timer

For configuring the self-timer for still images.

"Using Still Self Timer" (☞ p. 46)

Caution :

- Still Self Timer cannot be selected in the following cases.
 - During recording
 - When "System" is set to "High-Speed"
 - When "Rec Mode" is set to "Pre Rec" or "Time-Lapse Rec"

DIS

Camera shake during video recording can be effectively reduced.

"Reducing Camera Shake" (☞ p. 39)

Caution :

- DIS cannot be selected in the following cases.
 - During recording
 - When "System" is set to "High-Speed"
 - When "Rec Mode" is set to "Pre Rec" or "Time-Lapse Rec"
 - When "Live Streaming" is set to "On"

Settings Menu

Zoom

Sets the maximum zoom ratio.

■ When “System” is set to “4K”

Setting	Details
10X/Optical	Enables recording with 1 to 10x optical zoom. Set this when digital zoom is not desired.
200X/Digital	Enables recording with 1 to 10x optical zoom and 11 to 200x digital zoom.

■ When “System” is set to “HD”

Setting	Details
10X/Optical	Enables recording with 1 to 10x optical zoom. Configure this item when the use of digital zoom is not desired.
18(17)X/Dynamic	Enables recording with 1 to 10x optical zoom and 11 to 18x dynamic zoom when the image stabilizer is turned off. Enables recording with 1 to 10x optical zoom and 11 to 17x dynamic zoom when the image stabilizer is in the normal mode. Enables recording with 1 to 10x optical zoom and 11 to 16x dynamic zoom when the image stabilizer is in the active mode. Enables recording with 1 to 10x optical zoom and 11 to 12x dynamic zoom when the image stabilizer is in the powered active mode.
200X/Digital	Enables recording with 1 to 10x optical zoom, dynamic zoom in the zoom ratio according to the image stabilizer setting, and up to 200x digital zoom.

■ When “System” is set to “High-Speed”

The setting is fixed at “10X/Optical”.

Caution :

- Zoom ratio cannot be selected in the following cases.
 - During recording with “DIS” set to “On(Enh.AIS)”
 - When “DIS” is set to “On(Enh.AIS)” and “Rec Mode” set to “Pre Rec”
 - When “DIS” is set to “On(Enh.AIS)” and “Live Streaming” set to “On”

Tele Macro

Enables close-up shots when using the telephoto (T) end of the zoom.

“Taking Close-up Shots (TELE MACRO)” (E p. 40)

Memo :

- This is selectable only during Manual recording.

Flicker Correction

For setting whether to adjust image flicker that occurs under a fluorescent light.

Setting	Description
On	Enables flicker correction.
Off	Does not perform flicker correction.

Caution :

- Flicker Correction cannot be selected in the following cases.
 - When “System” is set to “High-Speed”
 - When “Frame Rate” is set to “24p”
 - When “Shutter Speed” is slower than “1/60”

Camera Process Menu

Focus

Focus can be adjusted manually.

“Adjusting Focus Manually (FOCUS)” (☞ p. 23)

Memo :

- This is selectable only during Manual recording.

Brightness Adjust

Adjusts the overall brightness of the screen.

“Adjusting Brightness” (☞ p. 26)

Caution :

- Brightness Adjust cannot be selected in the following cases.
 - During Auto recording
 - When “Shutter Speed”, “Aperture” and “Gain Up” are set to “Manual”
 - When “Backlight Comp” is set to “On”
 - When “Lolux” is set to “On”

Shutter Speed

Shutter speed can be adjusted.

“Setting Shutter Speed” (☞ p. 27)

Caution :

- During Auto recording
- When “Lolux” is set to “On”

Aperture

Adjusts the aperture value.

“Setting Aperture” (☞ p. 28)

Caution :

- Aperture cannot be selected in the following cases.
 - During Auto recording
 - When “Lolux” is set to “On”

Gain Up

Makes the subject appear bright automatically when recording in dark places.

“Increasing the Light Sensitivity Level” (☞ p. 29)

Caution :

- This function is not available for selection when “Lolux” is set to “On”.
- “Manual” is not available for selection in the Auto Recording mode.
- This function is fixed at “AGC” in the Auto Recording mode when “System” is set to “High-Speed”.
- “Auto Slow-Shutter” is not available for selection in the Manual Recording mode when “System” is set to “High-Speed”.

Backlight Comp

Corrects the image when the subject appears dark due to backlight.

“You can correct the image when the subject appears too dark due to backlight.” (☞ p. 30)

Caution :

- Backlight Comp cannot be selected in the following cases.
 - During Auto recording
 - When “System” is set to “High-Speed”
 - When “Shutter Speed”, “Aperture” and “Gain Up” are set to “Manual”
 - When “Lolux” is set to “On”

Settings Menu

Lolux

For configuring the Lolux mode (low-light recording mode) to increase the light sensitivity level at a dimly-lit location.

Setting	Description
On	Enables the Lolux setting.
Off	Disables the Lolux setting.

Memo :

- This is selectable only during Manual recording.
-

Detail

For adjusting the contour (detail) enhancement level.

Setting	Description
-10 to -1, 0, +1 to +10	Increasing the value increases the sharpness of the contour.
Off	Does not perform correction.

For adjustment of the details, go to "Detail Adjust Menu" (p. 104) .

Memo :

- This is selectable only during Manual recording.
-

Gamma

For adjusting the gamma curve that determines the gradation expression.

Setting	Description
Standard	Sets to a standard gamma curve.
Cinema	Sets to a gamma curve with similar gradation to the screen characteristics of movies.

Caution :

- Gamma cannot be selected in the following cases.
 - During Auto recording
 - When "WDR" is set to "On"
-

Level

Adjusts the corresponding gamma level when "Gamma" is set to "Standard" or "Cinema".

Setting	Description
-5 to -1, 0, +1 to +5	Increasing the value enhances the gradation of the shadows. However, the gradation of bright areas deteriorates. Decreasing the value enhances the gradation of the highlights. However, the gradation of shadows deteriorates.

WDR

When shooting subjects with a wide dynamic range, such as a backlit subject, this function compresses the dynamic range while maintaining image contrast by applying gradation compensation to the input video signals.

Setting	Description
On	Sets the wide dynamic range function to "On".
Off	Sets the wide dynamic range function to "Off".

Caution :

- WDR cannot be selected in the following cases.
 - During Auto recording
 - When "System" is set to "High-Speed"

White Balance

You can set the color tone to suit the light source.

"Setting White Balance" (p. 31)

For white balance adjustment, go to "White Balance Adjust Menu" (p. 105).

Memo :

- This is selectable only during Manual recording.

Color Matrix

Configures the color according to the user's preference using the color matrix (colors represented by the 3 R, G and B values).

Setting	Description
Standard	Sets to a standard color matrix.
Cinema Vivid	Sets to a vivid color matrix that is similar to the screen characteristics of movies.
Cinema Subdued	Sets to a subdued color matrix that is similar to the screen characteristics of movies.

Memo :

- This is selectable only during Manual recording.

Color Matrix Adjustment

The color matrix of the camera can be adjusted to suit the user's preference.

When shooting is performed using multiple cameras, the colors of the different cameras can be adjusted, and a color of the user's preference can be set on this camera. The saturation, hue and brightness of the primary and complementary colors (6 colors in total) can be configured individually.

The adjusted values of "Standard", "Cinema Vivid", and "Cinema Subdued" in Color Matrix can be stored individually.

Reset Process

Restores "Camera Process" to the default settings.

Caution :

- This item cannot be selected during recording.

Settings Menu

Detail Adjust Menu

Unavailable when "Detail" is set to "Off".

V/H Balance

For configuring whether to apply outline enhancement in the vertical (V) or horizontal (H) direction.

Setting	Description
V+4~V+1	Applies outline enhancement in the vertical (V) direction.
Normal	Standard outline enhancement.
H+1~H+4	Applies outline enhancement in the horizontal (H) direction.

Skin Detail

Detects the skin tone and applies effects for a more refined look.

Setting	Description
On	Enables "Skin Detail".
Off	Disables "Skin Detail".

Level

For configuring the smoothness of the outline in "Skin Detail".

Setting	Description
-3, -2, -1	For configuring the "Skin Detail" level. "-3" gives the maximum effect.

White Balance Adjust Menu

Preset Temp.

For selecting the color temperature when white balance is set to "Preset".

Setting	Description
2300K to 15000K	For selecting a color temperature setting.

MWB Paint

The red and blue components can be adjusted when white balance is set to "MWB A" or "MWB B".

* MWB is the abbreviation for Manual White Balance.

Setting	Description
-32 to +32	Increasing the value enhances the red and blue tones.

Memo :

- Separate settings can be specified for MWB A and MWB B.
-

Clear Paint After MWB

For configuring whether to restore the red and blue settings of MWB Paint to the default values when the  button is tapped for white balance to be adjusted automatically after white balance is set to "MWB A" or "MWB B".

Setting	Description
On	Restores the default values.
Off	Does not restore the default values.

AWB Paint

The red and blue components can be adjusted when white balance is set to "Auto".

* AWB is the abbreviation for Auto White Balance.

Setting	Description
-32 to +32	Increasing the value enhances the red and blue tones.

TC Menu

Caution :

- This item cannot be selected during recording.
-

TC Generator

For setting the operation of the time code.

“Changing the Mode of Time Code (TC) Recording” (☞ p. 47)

TC Preset

For configuring the time code (hour, minute, second, frame) when recording starts.

Unavailable when “TC Generator” is set to “Regen”.

Monitor Menu

Shooting Assist

For configuring settings on supplementary shooting functions.
Go to “Shooting Assist Menu” (p. 109) .

Grid Marker

For configuring whether to display a 3x3 grid on the screen.

Setting	Description
On	Displays grids.
Off	Does not display grids.

Display Settings

For configuring the displays on the LCD monitor screen.
Go to “Display Settings Menu” (p. 110) .

Auto Monitor Brightness

Automatically adjusts the brightness of the LCD monitor according to the brightness of the shooting location.

Setting	Description
On	Adjusts the LCD monitor brightness automatically.
Off	Does not adjust the LCD monitor brightness automatically.

Caution :

- Unavailable when “Silent Mode” is set to “Silent & Dim LCD”.

Monitor Brightness

For configuring the brightness level of the LCD monitor screen.

Setting	Description
-10 to -1, 0, +1 to +10	Increasing the value increases the brightness of the LCD monitor.

Memo :

- Available when “Auto Monitor Brightness” is set to “Off”.
- Changing the setting in “Monitor Brightness” does not affect the recorded videos.

Monitor Contrast

For configuring the contrast level of the LCD monitor screen.

Setting	Description
-10 to -1, 0, +1 to +10	Increasing the value increases the contrast of the LCD monitor. (The images appear sharper when the contrast is higher.)

Memo :

- Available when “Auto Monitor Brightness” is set to “Off”.
- Changing the setting in “Monitor Contrast” does not affect the recorded videos.

Settings Menu

LCD Backlight

For configuring the brightness of the LCD monitor backlight.

Setting	Description
-1, 0, +1	Increasing the value increases the brightness of the backlight.

Memo : _____

- Available when "Auto Monitor Brightness" is set to "Off".
 - Changing the setting in "LCD Backlight" does not affect the recorded videos.
-

Monitor Peaking

Adjusts the outline of the video image that is displayed on the LCD monitor.

Setting	Description
-3 to -1, 0, +1 to +3	Increasing the value enhances the outline of the video image.

Memo : _____

- Available when "Auto Monitor Brightness" is set to "Off".
 - Changing the setting in "Monitor Peaking" does not affect the recorded videos.
-

Shooting Assist Menu

Focus Assist

For setting whether to add color to the contour of the focused image upon switching the image to black-and-white.

Setting	Description
On	Enables the function.
Off	Disables the function.

Color

For setting the display color of the focused area when Focus Assist is activated.

Selecting "Multicolor" changes the outline color in sequence from red to green to blue according to the sharpness of the focus.

Setting	Description
Multicolor	Displays the outline in multicolors.
Blue	Displays the outline in blue color.
Green	Displays the outline in green color.
Red	Displays the outline in red color.

Zebra

For selecting whether to display zebra patterns at the bright areas of the subject.

Setting	Description
On	Displays the zebra pattern.
Off	Does not display the zebra pattern.

Top

For configuring the maximum luminance level for the zebra pattern display.

Setting	Description
5% to 95%, 98%, 100%, Over	For configuring the maximum luminance limit.

Bottom

For configuring the minimum luminance level for the zebra pattern display.

Setting	Description
0%, 5% to 95%, 98%, 100%	For configuring the minimum luminance limit.

Settings Menu

Display Settings Menu

Zoom

For configuring the display on the LCD monitor when zoom is operated.

Setting	Description
Number	Displays in numerical values.
Bar	Displays a zoom bar.
Off	No display

Focus

For configuring the unit of measurement for indicating the position of focus.

Setting	Description
Feet	Displays the position of focus in feet.
Meter	Displays the position of focus in meters.
Off	No display

Record Format

For configuring whether to display the recording format.

Setting	Description
On	Displays the recording format.
Off	No display

Media Remain

For configuring whether to display the SD card status and the remaining space on the card.

Setting	Description
On	Displays the SD card status and remaining space on the card.
Off	No display

TC

For configuring whether to display the time code.

Setting	Description
On	Displays the time code.
Off	No display

Audio Meter

For configuring whether to display the audio level meter.

Setting	Description
On	Displays the audio level meter.
Off	No display

Battery

For configuring whether to display the battery level.

Setting	Description
On	Displays the battery level.
Off	No display

Date/Time

For configuring whether to display the date and time.

Setting	Description
On	Displays the date and time.
Off	No display

Date Style

For configuring the date format.

Setting	Description
YMD, MDY1, MDY2, DMY1, DMY2	Select a date format.

Time Style

For configuring the time format (24-hour or 12-hour display).

Setting	Description
24-hour display 12-hour display	Select a time format.

A/V Set Menu

Video Set

For configuring settings related to the LCD monitor output.
Go to "Video Set Menu" (p. 112).

Audio Set

For configuring audio-related settings.
Go to "Audio Set Menu" (p. 112).

Video Set Menu

Display On TV

For configuring whether to display icons and date/time on the TV.

Setting	Details
On	Displays icons and date/time on TV.
Off	Does not display icons and date/time on TV.

HDMI Out

For configuring the HDMI Out resolution.

Setting	Details
Auto	It is recommended to select "Auto" usually.
480p or 576p	Select this when the video is not output in "Auto" correctly.

HDMI Control

Sets whether to link operations with an HDMI-CEC compliant TV.

Setting	Details
On	Turns on linked operations.
Off	Turns off linked operations.

Audio Set Menu

Zoom Mic

For configuring the zoom microphone. (Built-in microphone)

Setting	Details
On	Records audio sounds in the same direction as the zoom operation.
Off	Deactivates the zoom microphone.

Caution :

- This function is not available for selection when a microphone is connected to the mic terminal.

Memo :

- When "On" is selected, the volume level at the wide-angle (W) end is lower than that at the telephoto (T) end.

Audio Level

For configuring the audio level during recording on the Audio Level screen.

Caution :

- This function is not available for selection in the Auto Recording mode.

Wind Cut

Reduces the noise caused by wind.

Setting	Details
Auto	Activate the function automatically.
On	Activates the function.
Off	Deactivates the function.

Caution :

- This item cannot be selected during recording.
- This item is set to "Off" and cannot be changed when "Live Streaming" is set to "On".

K2 Technology

Reduces the degradation of sound quality caused by digital signal processing, and records a sound quality close to the original.

Setting	Details
On	Activates K2 Technology.
Off	Deactivates K2 Technology.

Caution :

- K2 Technology cannot be selected in the following cases.
 - During recording
 - When "System" is set to "4K" or "High-Speed"
 - When "Rec Mode" is set to "Pre Rec"
 - When "Live Streaming" is set to "On" (this item is set to "Off")

Operation Sound

For configuring the sound during operation.

Setting	Description
High	Increases the volume of the operating sound.
Low	Decreases the volume of the operating sound.
Off	No operating sound is output.

Caution :

- Operation Sound cannot be selected in the following cases.
 - During recording
 - When "Silent Mode" is set to "Silent" or "Silent & Dim LCD"
 - When "Rec Mode" is set to "Pre Rec"

System Menu

Record Set

For configuring settings related to the recording mode.
Go to "Record Set Menu" (p. 117).

Format SD Card

Deletes all files on the SD card.

Caution :

- Not available for selection when no SD card is inserted.
- All data on the SD card will be deleted when it is formatted.
Copy all files on the SD card to a computer before formatting.
- Make sure that the battery pack is fully charged or connect the AC adapter as the formatting process may take some time.

Restore SD Card

If, for some reason, no image is displayed on the index screen (thumbnail display) in the playback mode even though video images are stored in the SD card, performing SD card recovery may display the images.

Caution :

- Not available for selection when no SD card is inserted or during recording.
- Make sure that the battery is fully charged or connect the AC adapter as the recovery process may take some time.

Mobile User Guide

Displays the QR code to access the Mobile User Guide.

Memo :

- To read the QR code, a relevant application is required. Enter the URL in the internet browser manually if the QR code cannot be read.
- The Mobile User Guide is supported by Android devices and iPhone. It can also be viewed on standard browsers such as Google Chrome (Android) and Mobile Safari (iPhone).
- QR Code is a registered trademark of Denso Wave Incorporated.

Caution :

- This item cannot be selected during recording.

Silent Mode

The Silent mode is a function for turning off the operation sound. The screen can also be dimmed depending on the setting. Use this mode to record quietly in events such as recitals, presentations etc.

Setting	Description
Silent & Dim LCD	The LCD monitor screen darkens and no operating sound is output.
Silent	No operating sound is output.
Off	Disables the Silent mode.

Screen Lock

This function is used to lock the touch screen to prevent accidental operation when shooting under water.
"Locking the Screen (when Shooting Underwater)" (p. 9)

Caution :

- Screen Lock cannot be selected in the following cases.
 - During recording
 - When "System" is set to "High-Speed"
 - When "Rec Mode" is set to "Time-Lapse Rec"
 - When connected to Wi-Fi

LCD Closed Recording

During recording or while the camera is connected to Wi-Fi, closing the LCD monitor does not turn off the power of the camera. (The power turns off when Wi-Fi is disconnected.)

Setting	Details
On	Activates LCD Closed Recording.
Off	The unit is turned off when the LCD monitor is closed.

Caution :

- This item cannot be selected during recording.

Quick Restart

Enables the power to turn on quickly when the LCD monitor is opened again within 5 minutes.

Setting	Details
On	Enables Quick Restart.
Off	Deactivates the function.

Memo :

- When "On" is selected, power continues to be consumed for about 5 minutes after closing the LCD monitor. To minimize power consumption, select "Off".
- When "On" is selected, it is also possible to reduce power consumption by pressing and holding the "P.OFF" button in "MENU" to turn off the power. "Operating the Menu" (p. 97)

Caution :

- This item cannot be selected during recording.

Auto Power Off

When no operation is made for 5 minutes, this function turns off this unit or sets this unit to standby mode when using the AC adapter in case you forgot to turn off the power.

Setting	Details
On	Turns off the power automatically if this unit is not operated for 5 minutes.
Off	Power is not turned off even if this unit is not operated for 5 minutes.

Caution :

- This item cannot be selected during recording.

Demo Mode

Plays a demonstration of the special features of this unit.

Setting	Details
On	Plays a demonstration of the special features of this unit.
Off	Deactivates the function. (Recommended)

Memo :

- This item cannot be selected in the playback mode.
- Setting Demo mode to "On" may reset the record settings. Set to "Off" for normal use.

Caution :

- This item cannot be selected during recording.

Language

The language on the display can be changed.

"Changing the Display Language after Initial Settings are Configured" (p. 14)

Settings Menu

FACTORY PRESET

Returns all the settings to their default values.

Caution : _____

- This item cannot be selected during recording.
-

Date/Time

Resets the current time or sets to the local time when using this unit overseas.
“Readjusting the Clock after Initial Settings are Configured” (☞ p. 14)

Caution : _____

- This item cannot be selected during recording.
-

Time Zone

For configuring the UTC (Coordinated Universal Time) time difference in units of 30 minutes.

Caution : _____

- This item cannot be selected during recording.
-

Touch Screen Adjust

Adjusts the response position of the buttons on the touch screen.
“Adjusting the Touch Screen” (☞ p. 10)

Caution : _____

- This item cannot be selected during recording.
-

Network

For configuring the network.

When using the network function, select "On".

Setting	Description
On	Uses a network device.
Off	Does not use a network device.

Caution :

- Network cannot be selected in the following cases.
 - When "System" is set to "High-Speed"
 - When live streaming is in progress

Firmware Update

Updates the functions of this unit to the latest version.

For more details, please refer to the website below.

<http://www3.jvckenwood.com/english/support/index.html>

(When no program to update the software of this unit is available, nothing will be provided on the homepage.)

Caution :

- This item cannot be selected during recording.

System Information

Displays the version information and open source software licenses.

Record Set Menu

Record Format

For configuring settings related to the recording format.

Go to "Record Format Menu" (☞ p. 119) .

Rec Mode

For configuring the recording mode.

Setting	Description
Normal	When recording stops, the image, audio and accompanying data from the start till the end of the recording are recorded as a single scene.
Pre Rec	"Pre Rec Time" can be used to specify the number of seconds for video and audio to be recorded before the actual recording starts. "Pre Rec" (☞ p. 43)
Scene Continuous	This function enables several rounds of recordings (from the time when recording starts to the time when it is stopped) to be consolidated into a single scene. "Scene Continuous" (☞ p. 44)
Time-Lapse Rec	This function enables the changes of a scene that occur slowly over a long period of time to be played back within a short time by recording the number of frames configured in "Rec Frames" over the time interval configured in "Rec Interval". "Time-lapse Recording (Time-Lapse Rec)" (☞ p. 41)

Caution :

- Unavailable when "System" is set to "High-Speed".
- When this item is set to "Pre Rec", "Scene Continuous" or "Time-Lapse Rec", turning off the power will restore it to "Normal".

Settings Menu

Pre Rec Time

For configuring Pre Rec Time when “Rec Mode” is set to “Pre Rec”.

Setting	Description
15 sec	Records video and audio 15 seconds before actual recording starts.
10 sec	Records video and audio 10 seconds before actual recording starts.
5 sec	Records video and audio 5 seconds before actual recording starts.

Caution :

- When “System” is set to “4K”, the setting is fixed at “5 sec”.
-

Rec Frames

For configuring the number of frames to record when “Rec Mode” is set to “Time-Lapse Rec”.

Rec Interval

For configuring the recording time interval when “Rec Mode” is set to “Time-Lapse Rec”.

Slot Mode

For configuring the way to use the two card slots.

Setting	Description
Dual	Records simultaneously to the SD cards in both Slot A and Slot B. Both the SD cards in the two slots will contain the same files.
Series	Starts recording to the card in the other slot when the card in the slot where recording is in progress becomes full.

Caution :

- This function is not available for selection when “System” is set to “4K” or “High-Speed”.
-

4 GB Spanning

For configuring whether to split the files in units of 4 GB when recording to an SDXC card.

Setting	Description
On	Splits a file when it exceeds 4 GB or 30 minutes.
Off (SDXC)	Splits a file when it exceeds 64 GB or 4 hours.

Caution :

- Unavailable when “System” is set to “HD”.
-

Memo :

- This option is only valid if the SD card used for recording is of the SDXC card.
-

Video No. Reset

Resets the serial number of the video files.

By initializing the SD card when changing to a new one, you can record with the file number starting from “1” for each SD card. (File number of an AVCHD video file starts from “0”.)

Image No. Reset

Resets the serial number of the still image files.

By initializing the SD card when changing to a new one, you can record with the file number starting from “1” for each SD card.

Record Format Menu

Memo :

- The screen may darken for 5 to 6 seconds when settings in the recording format menu are changed.

System

For configuring the resolution of the video recordings.

Setting	Description
4K	Records in "4K" quality.
HD	Records in "HD" quality.
High-Speed	Records in "High-Speed" quality.

Memo :

- "4K" video recordings can be played back in 4K quality on TV sets that support 4K resolution and in HD quality in the case of high-definition TVs.

Format

Displays the file format of the recording.

Display	Description
AVCHD	Records in the AVCHD file format.
QuickTime	Records in the QuickTime file format (.mov).

Resolution

Displays the size of the recorded image. (Horizontal x vertical)

Display	Description
1920x1080	Records in 1920x1080 quality.
3840x2160	Records in 3840x2160 quality.

Frame Rate

For configuring the frame rate for recording.

And for configuring whether to perform progressive recording.

To capture scenes of a video as still images, progressive recording is recommended.

- When "System" is set to "4K": [Settings: 30p, 25p, 24p]
- When "System" is set to "HD": [Settings: 50p, 50i, 60p, 60i]
- When "System" is set to "High-Speed": [Settings: 50/25p, 100/25p, 60/30p, 120/30p, 100/50p, 120/60p]

Caution :

- When "System" is set to "HD", videos with "Frame Rate" at 60p/60i and 50p/50i cannot be mixed on the same card.
- Before inserting a new SD card, check if the "Frame Rate" has been set to the frame rate for shooting. (p. 128)
To change the "Frame Rate", do so before inserting a new card.

Bit Rate

For configuring the recording bit rate.

- When "System" is set to "4K", the setting is fixed at "70M".
- When "System" is set to "HD" and "Frame Rate" to "50p"/"60p", the setting is fixed at "28M".
- When "System" is set to "HD" and "Frame Rate" to "50i"/"60i": [Settings: 18M, 24M]
- When "System" is set to "High-Speed", the setting is fixed at "16M".

Settings Menu

Network Settings Menu

Web

For configuring settings related to web access.
Go to “Web Menu” (☞ p. 121) .

Live Streaming Set

For specifying settings for distributing live video images.
Go to “Live Streaming Set Menu” (☞ p. 122) .

Caution :

- Live Streaming Set cannot be selected in the following cases.
 - When “System” is set to “4K” or “High-Speed”
 - When “Rec Mode” is set to “Time-Lapse Rec”

Connection Setup

For configuring the network connection settings.
A wizard screen appears. Follow the instructions.
“How to Establish a Wi-Fi Connection” (☞ p. 78)

Caution :

- Connection Setup cannot be selected in the following cases.
 - While transferring still image
 - During live streaming

Reset Network

Restores the network settings to their default values.

Caution :

- Reset Network cannot be selected in the following cases.
 - During recording
 - During playback mode
 - While transferring still image
 - During live streaming

Web Menu

Web Access

To access via a web browser, set to "On".

Setting	Description
On	Enables web access.
Off	Disables web access.

Camera Name

For setting the name to be displayed on the web browser. Enter not more than 8 characters using the software keyboard.

Login Name (Fixed)

The login name is fixed at "jvc". Displays that are grayed out cannot be altered.

Login Password

Changes the password for accessing via a web browser.
The current password is displayed. Enter a new password directly.

Settings Menu

Live Streaming Set Menu

Live Streaming

Starts live distribution when "On" is selected.

Setting	Description
On	Starts live distribution.
Off	Does not start live distribution.

Caution :

- This item is fixed at "Off" during recording.
- This item cannot be selected when a network connection is not established (when the network connection icon is in a color other than white).

Server

For selecting the server for live streaming.

Streaming Server

For configuring the live streaming server.

Go to "Streaming Server Settings Menu" (☞ p. 123) .

Resolution

For setting the resolution of the video image during live distribution.

Setting	Description
1920x1080, 1280x720, 640x360	Values when "Frame Rate" of "Record Format" is set to "50p"/"60p".
1920x1080, 640x360	Values when "Frame Rate" of "Record Format" is set to "50i"/"60i".

Frame & Bit Rate

For configuring the frame rate and encoding bit rate of the video image during live distribution.

Setting	Description
50i/60i(12.0M), 50i/60i(8.0M), 50i/60i(5.0M), 50i/60i(3.0M)	Values when the mode (type) of transfer for video distribution is set to "MPEG2-TS/UDP", and "Resolution" of the live distribution videos is set to "1920x1080".
50i/60i(8.0M), 50i/60i(5.0M), 50i/60i(3.0M)	Values when the mode (type) of transfer for video distribution is set to "MPEG2-TS/RTP" or "RTSP/RTP", and "Resolution" of the live distribution videos is set to "1920x1080".
50i/60i(5.0M), 50i/60i(3.0M)	Values when the mode (type) of transfer for video distribution is set to "RTMP", and "Resolution" of the live distribution videos is set to "1920x1080".
25p/30p(8.0M), 25p/30p(5.0M), 25p/30p(3.0M), 25p/30p(1.5M)	Values when the mode (type) of transfer for video distribution is set to "MPEG2-TS/UDP", "MPEG2-TS/RTP" or "RTSP/RTP", and "Resolution" of the live distribution videos is set to "1280x720".
25p/30p(5.0M), 25p/30p(3.0M), 25p/30p(1.5M)	Values when the mode (type) of transfer for video distribution is set to "RTMP", and "Resolution" of the live distribution videos is set to "1280x720".
25p/30p(3.0M), 25p/30p(1.5M), 25p/30p(0.8M), 25p/30p(0.3M)	Values when "Resolution" of live distribution videos is set to "640x360".

Streaming Server Settings Menu

Alias

For setting a name to distinguish the settings of this camera.

Memo :

- The default values are Server1/Server2/Server3/Server4.
- You can enter up to 31 characters.

Type

For setting the system to transfer videos for distribution.

Memo :

- Use reception devices that are compatible with the respective transfer systems.
- The following items that can be set vary depending on the setting of this item.

Destination Address

For setting details such as the host name and the IP address of the live distribution destination.

Memo :

- Enter not more than 127 characters using single-byte alphanumeric characters (a to z, 0 to 9), single-byte hyphen "-" or dot ".".

Destination URL

For entering the URL of the live distribution destination beginning with "rtmp://".

There is no default value (blank).

Memo :

- You can enter up to 191 characters.

Destination Port

Enter the network port number of the live distribution destination using an integer between 1 and 65535.

The default value is 6504.

Memo :

- When "Type" is set to "MPEG2-TS/RTP", only even numbers from 2 to 65530 can be specified for the port number of the destination port.
- When "Type" is set to "MPEG2-TS/RTP" and "SMPTE 2022-1 FEC" is set to "On", N+2 and N+4 port numbers are also used in addition to the specified port number (N) of the destination port.

Stream Key

Enter the stream key specified at the live transmission destination.

There is no default value (blank).

Memo :

- You can enter up to 63 characters.

Password

Changes the password for RTSP authentication to enable client access.

There is no default value (blank).

Memo :

- You can enter up to 31 characters.

PCR Jitter

For configuring the setting to reduce PCR Jitter during live streaming.

Setting	Description
Low	Reduces PCR Jitter.
Normal	Choose this setting if the decoder is not functioning correctly.

Settings Menu

SMPTE 2022-1 FEC

Setting	Description
On	Uses FEC (Forward Error Correction).
Off	Does not use FEC (Forward Error Correction).

* The decoder must be compatible with SMPTE 2022-1.

FEC Matrix

For configuring the amount of "FEC" (Forward Error Correction) overhead when "SMPTE 2022-1 FEC" is enabled. The amount of FEC overhead changes when the L and D values are changed.

Memo :

- Increasing the amount of FEC overhead increases the packet loss resilience, but more network bandwidth is used.
 - Even with the same amount of overhead, increasing the L value will increase the packet loss (continuous packet loss) resilience.
-

Right Side

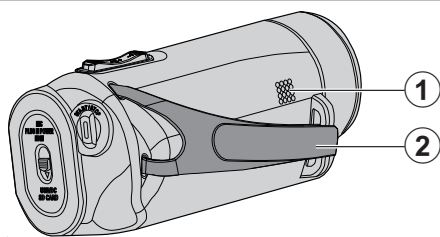

① Speaker

② Grip Belt

- Pass your hand through the grip belt to hold this unit firmly.

"Grip Adjustment" (☞ p. 7)

Bottom Side

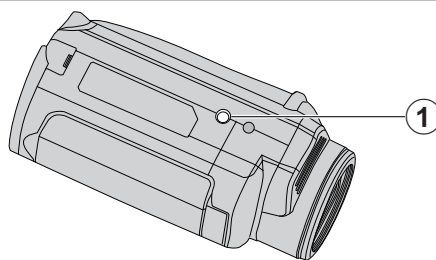

① Tripod Mounting Hole

"Tripod Mounting" (☞ p. 15)

Top/Left/Rear Side

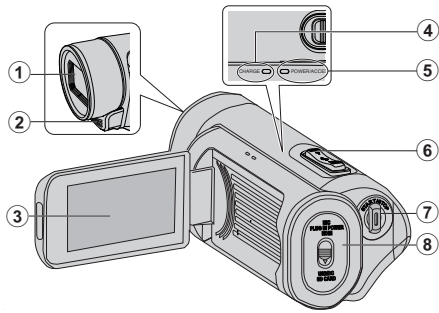

1 Lens

- The lens is protected by a protective glass cover.
- If the lens is dirty, use a commercially available lens blower to remove any dust, and a commercially available cleaning cloth to wipe off any dirt.
- Do not cover the front of the lens with your fingers during recording.

2 Stereo Microphone

- Do not cover the microphone with your fingers during video recording.

3 LCD Monitor

4 CHARGE (Charging) Lamp

- Lights up: Charging in progress
- Goes out: Charging finished
- Blinks: Charging error or abnormal temperature

5 POWER/ACCESS (Power/Access) Lamp

- Lights up/blinks during recording or playback.
Do not remove the SD card or any connecting cables.

6 Zoom/Volume Lever

- During shooting: Adjusts the shooting range.
- During playback (index screen): Moves to the next or previous page.
- During video playback: Adjusts the volume.

7 START/STOP (Video Recording) Button

- Starts/stops video recording.

8 Terminal Cover

Inside Terminal Cover

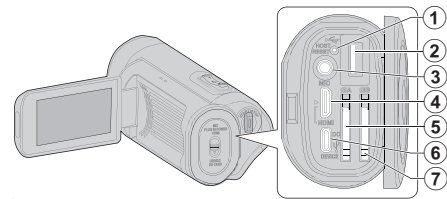

1 Reset Button

2 USB Host Terminal (Type-A)

3 Microphone Connector

- This unit does not come with a hot shoe for mounting an external microphone.
When using an external microphone, it is recommended that the microphone be secured with a commercially available straight bracket.

4 HDMI Mini Connector

- Connects to TV using an HDMI mini cable.

5 SD Card Slot A

- Insert an optional SD card.

6 DC/USB Device Terminal (Type-C)

- Connect to the AC adapter to perform charging.
It can also be used to connect the camera to a PC or Blu-ray recorder via a USB cable.

7 SD Card Slot B

- Insert an optional SD card.

LCD Monitor

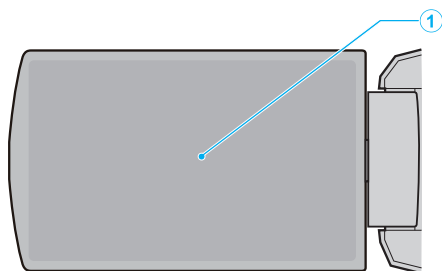

① LCD Monitor

- Turns the power on/off by opening and closing.
- Enables self-portraits to be taken by rotating the monitor.

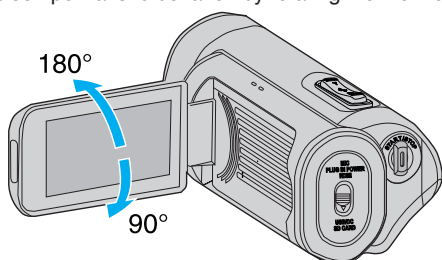

“Using the Touch Screen” (☞ p. 9)

“Names of Buttons and Functions on the LCD Monitor” (☞ p. 11)

Caution :

- Do not press against the surface with force or subject it to strong impact. Doing so may damage or break the screen.

Recording

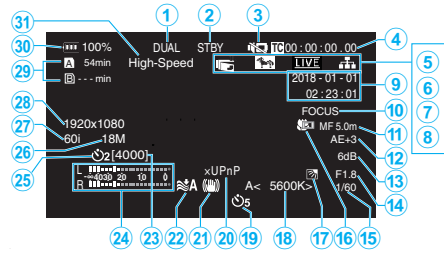

1 Simultaneous Recording (Dual Rec) Indicator

This item is not displayed when “Slot Mode” is set to “Series”.

2 SD Card Status

Display	Description
----	No card found in the selected slot
STBY	Recording standby
● REC	Recording
STBY	Pre Rec standby
● REC	Pre Rec in progress
STBY	Continuous Scene Rec standby
● REC	Continuous Scene Rec in progress
STBY	(Yellow text) Continuous Scene Rec paused
STBY	Time-lapse recording standby
STBY	(Yellow text) Time-lapse recording paused
● REC	Time-lapse recording in progress
STOP	Continues recording until the space on the SD card runs out
P.OFF	Power OFF

3 Silent Mode

“Silent Mode” (☞ p. 114)

4 Time Code (TC)

“Changing the Mode of Time Code (TC) Recording” (☞ p. 47)

5 LCD Closed Recording

Displayed when “LCD Closed Recording” is “On”.
Displayed in white during recording or when Wi-Fi is connected, and in gray in all other cases.

“LCD Closed Recording” (☞ p. 115)

6 Zebra

“Zebra” (☞ p. 109)

7 Live Streaming

The distribution status is displayed when “System”→“Network”/“Settings”→“Live Streaming Set”→“Live Streaming” is “On”.
“Live Streaming” (☞ p. 95)

Icon	Status
	Distribution in progress (good connection quality)
	Distribution in progress (poor connection quality)
	Connection pending or connection failed

8 Network Connection

The network connection status is displayed when “System”→“Network” is “On”. This icon is not displayed when “Off” is selected.
“Network” (☞ p. 117)

Icon	Status
	Connection is not established (starting up, preparing for connection)
	Connection is not established (preparing for connection)
	Connection is established
	When a USB adapter different from the connection settings is detected
(No display)	When an incompatible USB adapter is detected, or when “Network” is “Off”

9 Date/Time Display

Displays the current date and time.

Memo :

- The date/time display style can be configured in “Monitor”→“Display Settings”→“Date Style”/“Time Style” of the menu.

“Date Style” (☞ p. 111)

“Time Style” (☞ p. 111)

- The item is not displayed when “Monitor”→“Display Settings”→“Date/Time” of the menu is “Off”.

“Date/Time” (☞ p. 111)

10 Focus Assist

“FOCUS” is displayed when auto focus is activated.

11 Focus

No icon is displayed in the Auto Focus mode, but the Auto Focus icon (AF) and are displayed when “FaceDet” is activated, and the Auto Focus icon (AF) and are displayed when “AreaSel” is activated.
“Adjusting Focus Manually (FOCUS)” (☞ p. 23)

12 Brightness

No icon is displayed in the Auto mode, but is displayed when “AF+AE” is set to “FaceDet”, and is displayed when it is set to “AreaSel”.
“Adjusting Brightness” (☞ p. 26)

13 Sensitivity

Displays the gain value when “Gain Up” is set to the manual mode.
“LOLUX” is displayed when “Lolux” is “On”.
“Increasing the Light Sensitivity Level” (☞ p. 29)

14 Aperture

“Setting Aperture” (☞ p. 28)

15 Shutter Speed

“Setting Shutter Speed” (☞ p. 27)

16 Backlight Comp

“Setting Backlight Compensation” (☞ p. 30)

17 Tele Macro

“Taking Close-up Shots (TELE MACRO)” (☞ p. 40)

18 White Balance

Displays the current white balance mode.
(***K: Color temperature)

Display	Description
None	When “White Balance” is set to “Auto”
<FINE>	When “White Balance” is set to “Fine”
<CLOUD>	When “White Balance” is set to “Cloud”
<HALOGEN>	When “White Balance” is set to “Halogen”
<MARINE 1>	When “White Balance” is set to “Marine1”
<MARINE 2>	When “White Balance” is set to “Marine2”
P<***K>	When “White Balance” is set to “Preset”
A<***K>	When “White Balance” is set to “MWB A”
B<***K>	When “White Balance” is set to “MWB B”
blinking	When the white balance settings for “MWB A” and “MWB B” are activated

“Setting White Balance” (☞ p. 31)

19 Video Self Timer

“Using Video Self Timer” (☞ p. 45)

20 xUPnP

Displayed when UPnP cannot be used.
“Internet Connection” (☞ p. 81)

21 DIS

“Reducing Camera Shake” (☞ p. 39)

22 Wind Cut

“Wind Cut” (☞ p. 113)

23 Recordable Number of Still Shots

24 Audio Level Meter

25 Still Self Timer

“Using Still Self Timer” (☞ p. 46)

26 Bit Rate

27 Frame Rate

28 Resolution

29 Remaining Space on Recordable Media

“Checking the Remaining Battery Level and Recording Time” (☞ p. 48)

30 Battery Indicator

“Checking the Remaining Battery Level and Recording Time” (☞ p. 48)

31 High-Speed

“Slow-motion (High-speed) Recording” (☞ p. 34)

Thumbnail Screen

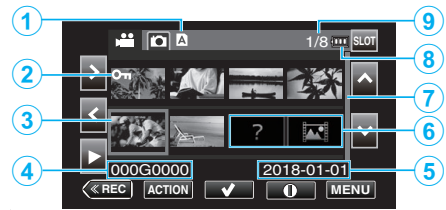

1 SD Card Information

Displays an icon that indicates the currently selected card slot and the status of the inserted SD card.

Display	Description
	Write-protect switch of the SD card in slot A is set to “LOCK”.
	Recovery or formatting is required for the SD card in slot B, or the SD card is incompatible.

2 Scene (File) Mark

Displays information on the scene (file).

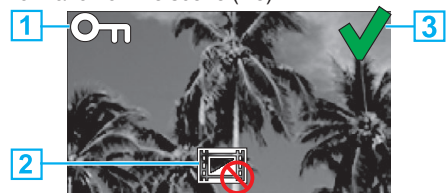

1 Protect Mark

- Scenes (files) that are appended with the Protect mark cannot be deleted with this unit.

2 Uneditable Mark

- Indicates scenes (files) for which Protect mark cannot be added or deleted or scenes (files) that cannot be deleted.

3 Check Mark

- A green check mark is displayed when a scene (file) is selected.
- A red check mark is displayed when the selection is confirmed.

3 Cursor

Scene (file) that is the currently active item. Move through the items using $\wedge \vee < >$.

4 Scene (File) Number

Displays the scene (file) number of the selected scene (file).

5 Recording Date

Displays the recording date of the scene (file).

6 Thumbnail Substitution Display



1 Scene (file) with corrupted management information. These scenes (files) cannot be played back.

2 Scene (file) that cannot be played back nor displayed in thumbnail with the current recording format settings.

7 Scroll Bar

- Indicates the scroll position.
- Black space below the scroll bar (white) indicates that there are more pages.
- When the scroll bar (white) is at the bottom, this indicates the last page.

8 Remaining Battery Power

- Displays the power status.

9 Number of Scenes (Files)

- Displays the scenes (files) for playback in the [serial number/total number of scenes (files)] format.

Video Playback

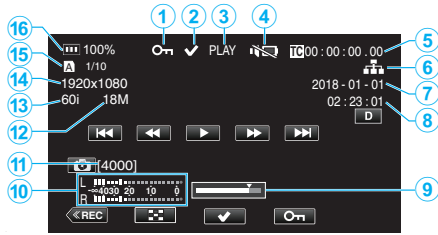

1 Protect Mark

“Protecting Video Images” (p. 63)

2 Check Mark

Displayed when the scene that is currently playing is selected.
This function is used for protecting a scene (file), canceling the protection of a scene (file) or deleting a scene (file) after playback.

“Selecting and Deleting Multiple Scenes” (p. 60)

“Protecting/Releasing Protection of Selected Files” (p. 63)

3 SD Card Status

PLAY: Now playing
STILL: Playback is paused
FWD*: High-speed playback in the forward direction (*playback speeds: 5x, 15x, 60x, 360x)
REV*: High-speed playback in the reverse direction (*reverse playback speeds: 5x, 15x, 60x, 360x)

4 Silent Mode

“Silent Mode” (p. 114)

5 Time Code (TC) Recorded in the Playback File

6 Network Connection Icon

“Network Connection” (p. 128)

7 Recording Date

8 Recording Time

9 Playback Position

10 Audio Level Meter

11 Recordable Number of Still Shots

12 Bit Rate

13 Frame Rate

14 Resolution

15 File Number of Current Playback File/Total Number of Files

16 Battery Indicator

“Checking the Remaining Battery Level and Recording Time” (p. 48)

Still Image Playback

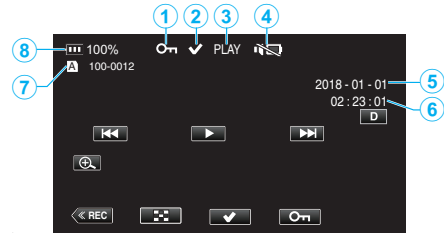

1 Protect Mark

“Protecting Video Images” (p. 63)

2 Check Mark

Displayed when the file that is currently playing is selected.
This function is used for protecting a scene (file), canceling the protection of a scene (file) or deleting a scene (file) after playback.

“Selecting and Deleting Multiple Scenes” (p. 60)

“Protecting/Releasing Protection of Selected Files” (p. 63)

3 PLAY: Slideshow playing now

4 Silent Mode

“Silent Mode” (p. 114)

5 Recording Date

6 Recording Time

7 Folder Number-File Number

8 Battery Indicator

“Checking the Remaining Battery Level and Recording Time” (p. 48)

When the unit is not working properly

Resetting this Unit

This unit is a microcomputer-controlled device. Electrostatic discharge, external noise and interference (from a TV, a radio, etc.) might prevent it from functioning properly. In that case, perform the steps below to reset this unit. (The recorded data will not be erased.)

- 1 Open the terminal cover.
 - Remove the power cord and all connecting cables.
- 2 Close the LCD monitor to turn off this unit.
- 3 Press the Reset button gently using an object with pointed tip.

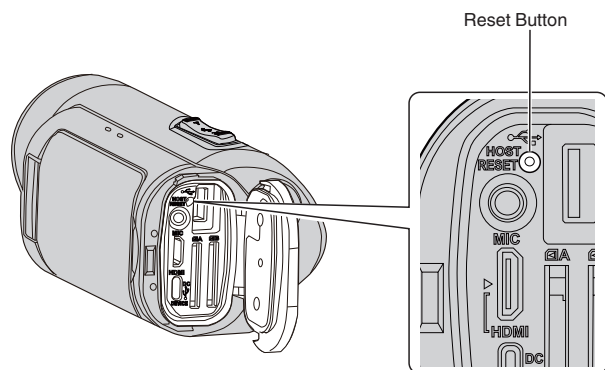

Charging

Unable to charge the battery.

- When the battery pack is fully charged, the lamp does not light up. Be sure to charge using the supplied AC adapter. Using an AC adapter that is not supplied with this camera may cause malfunction or damage of the unit. Malfunction or damage of the camera arising from the use of an AC adapter other than the one supplied is not covered in the warranty. Check the connection, followed by disconnecting and reconnecting the power bank cable. Charging cannot be performed under low or high temperature environments. Charge under the room temperature range of 10°C to 35°C. (Under environments beyond the temperature range, charging may stop to protect the battery pack.)
- Charging is not possible when the camera is turned on with "System" set to "4K" or "High-Speed".

The remaining battery display is not correct.

- If this unit is used for long periods of time in high or low temperatures, or if the battery pack is repeatedly charged, the amount of remaining battery may not be displayed correctly.

The battery runs out quickly even after charging.

- Be sure to charge using the supplied AC adapter. Malfunction in the unit that occurred due to the use of an AC adapter other than the one provided is not included in the warranty. The performance of the battery will drop temporarily when the temperature is -10°C to 0°C, this will cause the remaining recording time to shorten. When the recording time becomes extremely short even when the battery is fully charged, the battery needs to be replaced. Malfunction of the built-in battery due to the conditions of storage or use and deterioration in its performance over time are not covered by the warranty even during the warranty period. Users will need to pay for servicing and repair in these cases. For more information, please consult your nearest service center.

Power supply

Unable to turn on the power.

- Check whether the AC adapter is properly connected. See “Charging” (☞ p. 6) .
- When the unit does not turn on even after charging, reset the unit. “When the unit is not working properly” (☞ p. 131)

Recording

Recording cannot be performed.

- Check whether the inserted SD card supports the current recording format.
- Check whether the Write Protect switch of the SD card is set to “LOCK”.
- Set to the recording mode by tapping the  button on the screen.

Recording stops automatically.

- Recording stops automatically as it cannot be performed for 12 or more consecutive hours according to specifications. (It may take some time to resume recording.)
- Turn off this unit, wait for a while, and turn it on again. (This unit stops automatically to protect the circuit when the temperature rises.)

The focus is not adjusted automatically.

- If you are recording in a dark place or a subject that has no contrast between dark and light, adjust the focus manually.

“Adjusting Focus Manually (FOCUS)” (☞ p. 23)

- Wipe the lens with a lens cleaning cloth.
- Cancel manual focus on the manual recording menu.

“Adjusting Focus Manually (FOCUS)” (☞ p. 23)

The inside of the lens is foggy.

- Open the terminal cover; close the LCD monitor and leave as is for a while to reduce the temperature.

Preventing fogging inside the lens

- Models with waterproof function are airtight. When the temperature rises during recording, condensation can occur inside the lens due to the internal humidity.

■ During recording

- To prevent the temperature of this unit from rising, we recommend that you use the unit in the following ways.
 - 1 Avoid frequent exposure to direct sunlight. Record under the shade or use an umbrella. Best if you could keep a wet towel cover the unit.
 - 2 The use of a tripod is recommended. Long hours of recording while holding the unit in your hands will cause the temperature of the unit to rise.
 - 3 It is better to leave the terminal cover open while recording. However, the waterproof, dust-proof and shockproof features do not function in this condition. Do take note of the environment when using the camera. (Do not use a wet towel.)
 - 4 Make sure to turn off the power when you are not recording. When the LCD monitor is closed, the unit turns off.
 - When “Quick Restart” is “On”, power continues to be consumed for about 5 minutes after closing the LCD monitor screen.

■ During charging

- It is recommended to charge the unit in a low humidity environment.
- The moist air inside the unit can cause condensation.
- We recommend that you charge the unit in a room where humidifier is not in use, and in an air-conditioned room during summer.

The record settings have changed.

- When “Demo Mode” is set to “On”, the record settings may reset. Set “Demo Mode” to “Off” for normal use.

“Demo Mode” (☞ p. 115)

SD Card

Cannot insert the SD card.

- Make sure not to insert the SD card in the wrong direction.
“Inserting an SD Card” (☞ p. 8)
- Do not use a miniSD card or microSD card on this unit (even if the card is inserted in an adapter). It may cause malfunction.
“Types of Usable SD Card” (☞ p. 8)

Unable to copy to SD card.

- To use a new SD card or SD card that was used on other devices, it is necessary to format (initialize) the SD card using “Format SD Card” in the “System” menu.
“Format SD Card” (☞ p. 114)
- When “Check Card’s Write Protection Switch” appears, release the lock on the SD card.

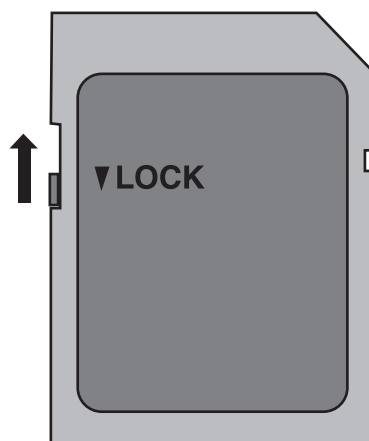

SD card cannot be removed.

- The inability to remove the SD card may be due to adhesion of dust, etc. Use a pair of tweezers to pull out the SD card, remove the dust and then re-insert the card.

Playback

Sound or video is interrupted.

- Sometimes playback is interrupted at the connecting section between two scenes. This is not a malfunction.

There is no sound.

- When the Silent mode is used, operation sounds will not be output. Turn off the Silent mode.
“Silent Mode” (☞ p. 114)
- Operation sound is not output when “Operation Sound” is set to “Off”. Select “Low” or “High”.
“Operation Sound” (☞ p. 113)
- Audio sound is not recorded for videos taken in High-Speed.
“Slow-motion (High-speed) Recording” (☞ p. 34)
- Audio sound is not recorded for videos taken in Time-Lapse Rec.
“Time-lapse Recording (Time-Lapse Rec)” (☞ p. 41)

The same image is displayed for a long time.

- Clean the terminals of the SD card with a dry cotton swab or something similar.
- Execute “Format SD Card” in the “System” menu. (All data will be deleted.)
“Format SD Card” (☞ p. 114)

The motion is choppy.

- Clean the terminals of the SD card with a dry cotton swab or something similar.
- Execute “Format SD Card” in the “System” menu. (All data will be deleted.)
“Format SD Card” (☞ p. 114)
- Verify the system requirements of your PC when using CyberLink PowerDirector to play back.
“Verifying System Requirements (Guideline)” (☞ p. 74)

Images do not appear on the TV properly.

- Disconnect the cable and connect again.
“Connecting via the HDMI Mini Connector” (☞ p. 57)
- Reset this unit.
“Resetting this Unit” (☞ p. 131)

Images are projected vertically on the TV.

- Adjust the TV’s screen accordingly.

When connected to the TV via the HDMI mini cable, proper images and sounds are not output.

- Images and sounds may not be output properly depending on the TV connected. In such cases, perform the following operations.
1 Disconnect the HDMI mini cable and connect it again.
“Connecting via the HDMI Mini Connector” (☞ p. 57)

When connected to the TV via the HDMI mini cable, displays such as buttons on the screen are slow to appear.

- Depending on the type of TV connected, this symptom is normal and not a malfunction.

Editing/Copying

Unable to delete file.

- Files (videos/still images) that are protected cannot be deleted. Release protection before deleting the file.
“Protecting Video Images” (☞ p. 63)

Computer

Unable to copy files to DVD or Blu-ray disc with a PC.

- To record to discs, a recordable DVD or Blu-ray drive is required for the computer in use.

The computer cannot recognize the SDXC card.

- Confirm and update the OS of your computer.
“When your computer cannot recognize the SDXC card” (☞ p. 9)

Screen/Image

Color and brightness of the screen changes and horizontal stripes and flickers appear on screen

- For images recorded under lighting from fluorescent or mercury lamps, the color and brightness of the screen may change and horizontal stripes and flickers may appear on the screen, but this is not a malfunction.
- If the image stabilizer has been set to “On(AIS)”, switch to “On” to improve the condition.

“Reducing Camera Shake” (☞ p. 39)

A band or a ball of bright light appears on the LCD monitor.

- Change the direction of this unit to prevent the light source from coming into view. (A band or a ball of bright light may appear when there is a bright light source near this unit, but this is not a malfunction.)

The recorded subject is too dark.

- Use backlight compensation when the background is bright and the subject is dark.

“Setting Backlight Compensation” (☞ p. 30)

- Use “Gain Up” in the menu.

“Gain Up” (☞ p. 101)

- Set “Brightness Adjust” in the Camera Process menu to the “+” side.

“Adjusting Brightness” (☞ p. 26)

The recorded subject is too bright.

- Set the backlight compensation to “Off” if it is being used.

“Setting Backlight Compensation” (☞ p. 30)

- Set “Brightness Adjust” in the Camera Process menu to the “-” side.

“Adjusting Brightness” (☞ p. 26)

- The use of a commercially available ND filter is recommended for recording under extremely bright conditions. (Filter diameter: 46 mm)

The color looks strange. (Too bluish, too reddish, etc.)

- Wait for a while until natural colors are achieved. (It may take some time for white balance to be adjusted.)

- Configure “White Balance” in the Camera Process menu. Select from “Fine”/“Cloud”/“Halogen” according to the light source. Select “Preset” and configure the color temperature to an appropriate setting. Select “MWB A” or “MWB B” and adjust accordingly.

“Setting White Balance” (☞ p. 31)

The color looks different.

- Configure “White Balance” in the Camera Process menu.

“Setting White Balance” (☞ p. 31)

There are bright or dark spots on the screen.

- While the LCD monitor screen has more than 99.99% effective pixels, 0.01% of the pixels may be bright spots (red, blue, green) or dark spots. This is not a malfunction. The spots will not be recorded.

Other Problems

The buttons on the touch screen do not work.

- Tap the buttons on the touch screen with your fingers.
The buttons may not respond if you touch them with your fingernails or with gloves on.
- Disable “Screen Lock”. You cannot operate the touch panel when “Screen Lock” is enabled.

“Locking the Screen” (☞ p. 37)

The image is grainy.

- When digital zoom is used, the image becomes grainy as it is digitally enlarged.

This unit heats up.

- This is not a malfunction. (This unit may become warm when used for a long time.) Stop using the unit if it gets too warm.

The language on the display changed.

- It may occur when you connect this unit to a TV with different language setting using an HDMI mini cable.

“Operating in Conjunction with TV via HDMI” (☞ p. 58)

When connected to the TV via the HDMI mini cable, proper images and sounds are not output.

- Images and sounds may not be output properly depending on the TV connected. In such cases, perform the following operations.

1 Disconnect the HDMI mini cable and connect it again.

2 Turn off and on this unit again.

“Connecting via the HDMI Mini Connector” (☞ p. 57)

HDMI-CEC functions do not work properly, and the TV does not work in conjunction with this unit.

- TVs may operate differently depending on the specifications, even if they are HDMI-CEC compliant. Therefore, the HDMI-CEC functions of this unit cannot be guaranteed to operate in combination with all the TVs. In such cases, set “HDMI Control” to “Off”.

“HDMI Control” (☞ p. 112)

The media remaining indication blinks without displaying the time.

- The indication blinks while the SD card is being recognized.
The camera takes some time to recognize the SD card when there are many recorded files on the SD card. In this case, back up the recorded files on a PC and format the SD card, or insert a new SD card.

“Format SD Card” (☞ p. 114)

This unit does not function properly and error messages appear.

- This unit is a microcomputer-controlled device. Electrostatic discharge, external noise and interference (from a TV, a radio, etc.) might prevent it from functioning properly. In such a case, close the monitor screen to turn off the power and remove the AC adapter, then press the Reset button to reset this unit.

“Resetting this Unit” (☞ p. 131)

CHARGE lamp and POWER/ACCESS lamp are blinking and operation is disabled

- Close the monitor screen to turn off the power and remove the AC adapter, then press the Reset button to reset this unit.

“Resetting this Unit” (☞ p. 131)

- If these operations won't solve the problem, contact your JVC dealer or the JVC service center.

Disclaimer

- We shall not be liable for any loss of recorded contents when videos or audio cannot be recorded or played back properly due to malfunction of this unit and accessories that come with it or the SD card.
- Recorded contents (data) that are lost, including loss due to malfunction of this unit, cannot be restored. Please be forewarned.
- JVC will not be responsible for any lost data. Please be forewarned.
- Defective recordable media that have been replaced may be used in our analysis for the purpose of quality improvement. Therefore, it may not be returned.

Error Message

No Media/No Media

- Insert an SD card into one of the card slots or both slots.

Formatting Required

- Remove the SD card, back up the data on a PC, and insert the card again. Tap “Yes” when the formatting confirmation screen appears.

Check the Speed Class or Type of the Card

- Check that the card is supported by this unit.

“Types of Usable SD Card” (☞ p. 8)

Recording Failure

- Reset this unit.

“Resetting this Unit” (☞ p. 131)

Turn on the function in the menu to split the file into units of 4 GB.

- Recording is not possible with SD cards other than those of the SDXC format when “4 GB Spanning” is “Off”. To perform recording with “4 GB Spanning” set to “On”, use an SDXC card.

This Card Cannot Be Used for Recording or Editing on This Camera

- The Frame Rate set on this unit is different from the Frame Rate recorded in the SD card. Please change the Frame Rate.
- After backing up the data, run “Format SD Card” from the “System” menu.

Check Card's Write Protection Switch

- Set the write protect switch of the SD card to off.

Media Full!

- Delete files, or move files to a computer or other devices.
- Replace the SD card with a new one.

Scene Quantity Limit Exceeded

- Move the files or folders to a computer or other device. (Back up your files.)

File Quantity Limit Exceeded

- Move the files or folders to a computer or other device. (Back up your files.)

Camera Temperature Is Too High, Power Will Turn Off to Protect the Camera

- Turn on the power after the camera has cooled down.

Perform regular maintenance of this unit to enable it to be used for a long time.

Caution :

- Be sure to detach the AC adapter and power plug before performing any maintenance.

Camcorder

- Wipe this unit with a dry, soft cloth to remove any dirt.
- When it is extremely dirty, soak the cloth in a solution of neutral detergent, wipe the body with it, and then use a clean cloth to remove the detergent.

Caution :

- Do not use solvents such as benzene, thinner, or alcohol. Doing so may cause damage to the unit.
- When using a chemical cloth or cleaner, be sure to observe the warning labels and instructions of the product.
- Do not leave the device in contact with rubber or plastic products for a long time.

Lens/LCD Monitor

- Use a lens blower (commercially available) to remove any dust, and a cleaning cloth (commercially available) to wipe off any dirt.
Mold may form if the lens is left dirty.
- You can use a commercially available anti-reflection or protective film on the screen.
However, depending on the thickness of the film, operations on the touch screen may not be performed smoothly or the screen may darken slightly.

After using underwater or on the beach

- For care and cleaning where there is mud or dirt on the camera after using underwater or on the beach, read “Before Using Underwater or under Low Temperature” (p. 18) .

Specifications

Camera

Item	Details
Power supply	Using AC adapter: DC 5 V
Power consumption	4.1 W (when "System" is set to "4K", "Frame Rate" is set to "25p" and "LCD Backlight" is set to "0") Rated Current Consumption: 3A
Dimensions (mm)	79 x 76 x 162 (W x H x D: excluding grip belt)
Mass	Approx. 620 g (camera only)
Operating environment	Allowable operating temperature: -10 °C to 40 °C Allowable storage temperature: -20 °C to 50 °C Allowable charging temperature: 10 °C to 35 °C Allowable relative humidity: 35 % to 80 %
Image pickup device	1/2.3" 18,910,000 pixels (CMOS, back-illuminated)
Recording area	6,650,000 to 7,950,000 pixels (image stabilizer: off)
Lens	F1.8 to F2.8 f= 3.76 mm to 37.6 mm 35 mm conversion: 29.9 mm to 299 mm (image stabilizer: off)
Filter diameter *	46 mm (screw pitch: 0.75 mm)
Lowest illumination	3 lux
Zoom	Optical zoom: Up to 10x Dynamic zoom: Up to 18x Digital zoom: Up to 200x
LCD monitor	3.0" Wide, 460,000 pixels, color LCD
Recording media	SDHC/SDXC card (commercially available) "Types of Usable SD Card" (p. 8)
Built-in battery	Type: Lithium-ion battery Rating: DC3.6 V 6400 mAh

* When a lens filter or conversion lens is attached, vignetting (the screen getting dark, or appearance of shadows) may occur.

Connectors

Item	Details
HDMI output connector	HDMI mini connector
USB host terminal	USB Type-A, USB 2.0-compliant
DC/USB device terminal	USB Type-C, USB 2.0-compliant
Microphone connector	Φ3.5 mm mini jack (stereo)

Video

Item	Details
Recording/ Playback format	4K: QuickTime file format Video: MPEG-4 AVC/H.264 Audio: LPCM 2ch No. of recording pixels: 3840 x 2160 HD: AVCHD file format Video: MPEG-4 AVC/H.264 Audio: Dolby Digital 2ch No. of recording pixels: 1920 x 1080 High-Speed: QuickTime file format Video: MPEG-4 AVC/H.264 Audio: nil No. of recording pixels: 1920 x 1080
Extension	4K/High-Speed : .MOV HD: .MTS
Bit rate	4K: up to approx. 70 Mbps HD: up to approx. 28 Mbps, up to approx. 24 Mbps, up to approx. 18 Mbps High-Speed: up to approx. 16 Mbps
Sound quality (Audio)	4K: 48kHz/16bit HD: 48kHz/16bit, 256kbps

Still Image

Item	Details
Recording format	JPEG standard
Extension	.JPG
Image Size (Recording pixel count)	(16:9 aspect ratio) 4K: 3840 pixels x 2160 pixels (8.3 M) HD: 1920 pixels x 1080 pixels (2 M) "Approximate Number of Still Images (Unit: Number of Shots)" (p. 50)

AC Adapter (UNI318-0530)

Item	Details
Power supply	AC 100 V to 240 V, 50 Hz/60 Hz
Output	DC 5 V, 3 A
Allowable operating temperature	0°C to 40°C (10°C to 35°C during charging)
Dimensions (mm)	75 x 29.8 x 50.6 (W x H x D: excluding cord and plug)
Mass	Approx. 125 g

Memo :

- The specifications and appearance of this product are subject to changes for further improvement without prior notice.

Trademarks

- AVCHD Progressive and AVCHD Progressive logo are trademarks of Panasonic Corporation and Sony Corporation.
- The terms HDMI and HDMI High-Definition Multimedia Interface, and the HDMI Logo are trademarks or registered trademarks of HDMI Licensing Administrator, Inc. in the United States and other countries.
- Manufactured under license from Dolby Laboratories. Dolby, Dolby Audio and the double-D symbol are trademarks of Dolby Laboratories.
- SDXC logo is a trademark of SD-3C LLC.
- Microsoft and Windows are either registered trademarks or trademarks of Microsoft Corporation in the United States and/or other countries.
- Mac, OS X, QuickTime, iMovie, iPhoto, iPhone and Safari are trademarks of Apple Inc., registered in the U.S. and other countries.
- Intel and Intel Core are trademarks or registered trademarks of Intel Corporation in the United States.
- Android, YouTube and Chrome are trademarks or registered trademarks of Google Inc.
- The company name of Fontworks, Fontworks, and the name of the fonts are registered trademarks of Fontworks Inc.
- QR Code is a registered trademark of Denso Wave Incorporated.
- Other product and company names included in this instruction manual are trademarks and/or registered trademarks of their respective holders.
- Marks such as ™ and ® have been omitted in this manual.

JVC